

HRVS-DN

Medium Voltage Digital Soft Starter 30-2700A, 1500-15000V



For Every New Beginning
You Need A Good Start



SOLCON

HRVS-DN

HRVS-DN

General

This advanced, micro-processor controlled through fiber optic links, Medium Voltage soft starter is designed for use with standard asynchronous and synchronous motors.

The HRVS-DN is a highly sophisticated digital soft starter which ensures smooth, stepless acceleration and deceleration, eliminating current and mechanical shocks to the motor and load.

Standards

○ CE & Gost-R

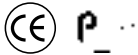

○ Marine & Offshore:

Lloyds, GL, ABS, BV, DNV, RINA Subject to individual case approval



Unique Standards

The HRVS-DN and its enclosure are manufactured under ISO 9001:2000 and according to the applicable parts of the following standards:

IEC 62271-200	High Voltage switchgear and controlgear	IEC 129	Earthing switch
IEC 60061	High Voltage test techniques, General definitions and test requirements (BIL)	IEC 60470, UL 347	Vacuum contactors
CE	Upon Request	IEC 282-1	Vacuum contactors + fuses
IEC 60694	Common specifications for high voltage switchgear and controlgear standard	IEC 60282-1+IEC 420	Medium voltage fuse
IEC 71-1/2	Insulation co-ordination	DIN 43624	Fuse base for indoor mounting
EN 50178:1998	Electronic equipment for use in power installation	DIN 46234	Cable lugs
IEC 664	Insulated coordination within low-voltage systems and including clearances and creepage distances for equipment	DIN 0472+IEC 754	Medium voltage cables
EN 60265-1	Load break switch	EN 61000-6-2	Electromagnetic compatibility (EMC)- Immunity
EN 60420	Load break switch	EN 61000-6-4	Electromagnetic compatibility (EMC)- Emission
IEC 129	Double section rotary disconnectors	EEC/72/23	Electrical safety-Council Directive
		UL 347	High voltage industrial control equipment
		UBC 1, 2, 3, 4	Universal Building Code for Zones I - 4

■ Medium Voltage Compartment

■ Low Voltage Compartment

Multi-layered description of the standard cabinet

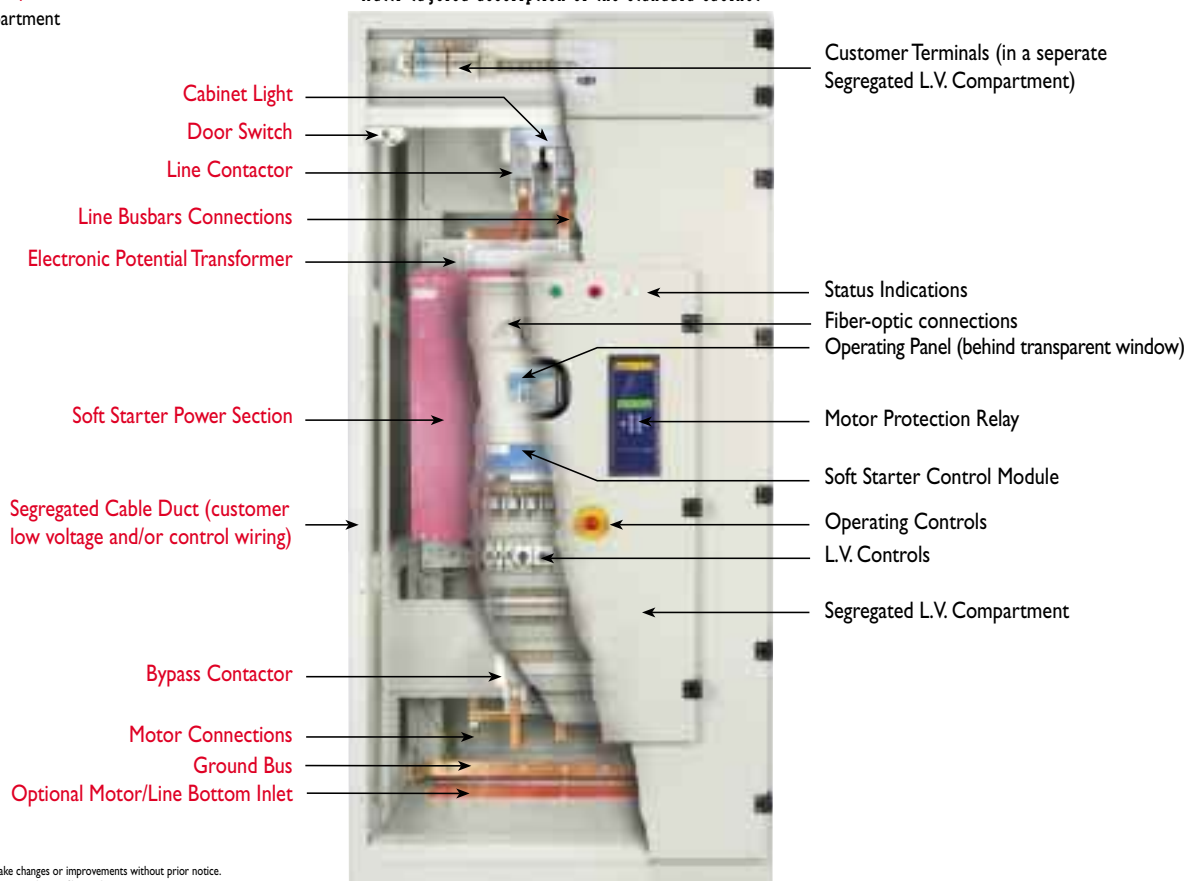

Features

Advantages at a Glance

- Heavy duty design at 50°C ambient temperature
- Reduced inrush current and mechanical shock
- Third generation microprocessor circuitry
- Soft, stepless acceleration & deceleration
- Unique starting & stopping characteristics
- Sophisticated motor protection package
- User friendly, easy setup and operation
- IP32-standard, higher protection by special order
- Synchronous motor starting, utilizing unique module
- Innovative low voltage test modes - full testing with a small L.V motor using standard built in features and "dry" cabinet automation test
- Advanced Electronic Potential Transformer utilizing Patent Pending "wireless" voltage measurement system
- Unique, Patent Pending fiber-optic firing system providing complete isolation between MV and LV compartments.
- Unique fault indication down to the individual thyristor level
- Fully featured motor insulation circuitry (optional)
- Each starter is tested for Partial Discharge (Korona) improving safety and ensuring long term reliability according to EN50178/625.1
- Power factor capacitors can be connected directly to the upstream contactor (omitting the need for capacitor contactor)
- Two optional methods of delivery: Chassis type for self assembly or Complete system
- RS485 Communication with MODBUS, PROFIBUS or MODBUS/TCP protocols (others - upon request)
- Wide 45-65Hz Auto-tracking frequency range combining special software with unique hardware arrangement (designed for Marine, Offshore and Generators operating under continuous frequency variation)

Motor & Starter Protection

- Too many starts & start inhibit time
- Long start time (Stall protection)
- Electronic overload with selectable curves
- Electronic shear-pin (1-8.5 FLA During "Run")
- Electronic motor overcurrent protection (8.5 FLA during "Start")
- Electronic starter overcurrent protection (8.5 FLC always active)
- Undercurrent
- Unbalanced current
- Ground fault current
- Phase loss
- Phase sequence and under/over frequency
- Undervoltage
- Overvoltage
- External faults (2 separate inputs)
- Shorted SCR & Wrong Connection
- Starter over temperature
- Power on without start signal
- Open Bypass contactor

Starting & Stopping

- Soft start and soft stop
- Current limit
- Pump Control characteristics
- Torque and Current Control for optimized Starting & Stopping processes
- Dual Adjust - 2 start/stop characteristics for varying loads and two speed motors
- Pulse start (kick start 70-700% FLA, 0-10sec)
- Tacho/encoder feedback (option)

Interactive LCD Display

Six languages can be selected: English, French, German & Spanish (Chinese and Russian - optional)



LEDs - For easy operational status

User friendly keypad allows accurate setting

Control Circuitry

- Multi-function programmable I/Os
- Opto-isolated control inputs
- Three Change Over output relays, 8A/250VAC
 - "Immediate" - upon Start
 - "End of Acceleration"
 - "Fault" programmable as Trip or Trip Fail-safe
- Analogue output 0/4-20mA, 0-10VDC
- Tacho incremental encoder feedback

Versions including disconnect switch



Four compressors in a multistart configuration (6600V, 250A). The redundant supply is mechanically and electrically interlocked. A pair of vacuum contactors controls the mains supply. Each motor is Individually equipped with electro-mechanically interlocked load make fault break disconnect switch in addition to vacuum line and bypass contactors.



All in one configuration, incoming compartment with load make fault break disconnect switch and fuses. Power section containing the power module with vacuum type line and bypass contactors. (Pumps 4160V, 400A 3000MOSL). Tested for BIL60KV



Incoming cabinet, with load make fault break disconnect switch, three fuses and a line contactor. Power section cabinet contains power module, bypass vacuum contactor and motor terminals. (Air Compressor 3300V, 250A).

Applications

Advantages at a Glance - Synchronous Motors

- Static exciter range: 60-240Vdc, 40-1000A
- Static or rotating exciter (drawn below as Static exciter)
- System initiation at end of asynchronous starting process
- Pull out protection
- Full motor protection features using the MPS-3000
- Single motor continuous field current control

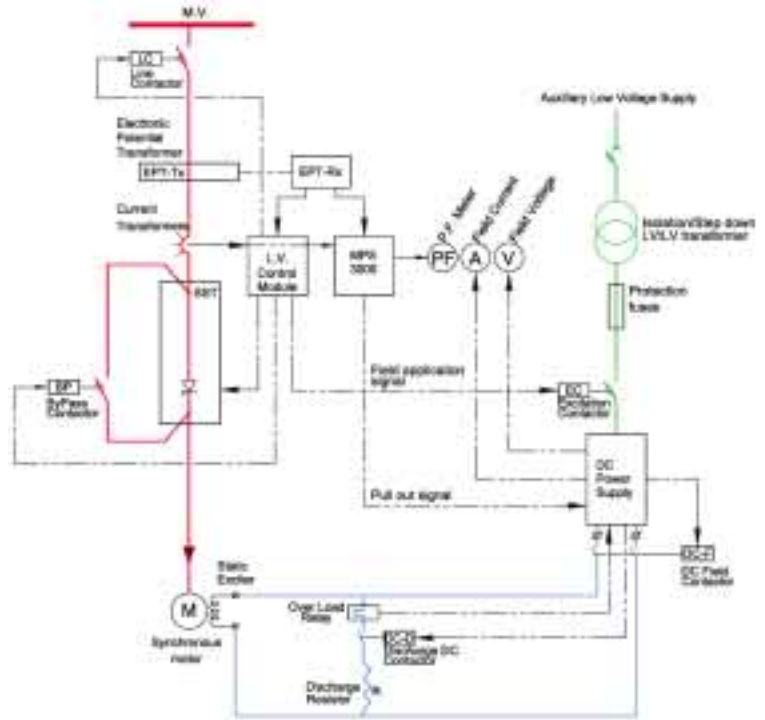

Industrial Applications - Asynchronous and Synchronous Motors

- Pumps
- Compressors and chillers
- Fans, Blowers and centrifuges
- Conveyors, elevators and monorail systems
- Tachometer driven systems
- Starting from weak power supply (diesel generators, long supply lines, etc)



China
Liquid Gas Booster Compressor
6600V / 600A



Turkey
Three City Municipality Fresh Water Pumps
3300V / 300A



Mexico
Four City Municipality Water Pumps
at 4160V / 400A elevating Fresh
water to 1800 Meters



Tanzania
Four Air Supply Fans in a Gold-Mine
6600V / 300A

Marine, Offshore, Oil & Gas Applications

- LNG & LPG pumps (mainly in multi-start application)
- Water & ballast pumps
- Refrigeration chillers & compressors
- Hydraulic pumps & power packs
- Thrusters
- Main propulsion motors
- Unique protection for corrosive environments
- Generator ready - auto frequency tracking, sustains variations of 45-65Hz while starting



Four Crude oil pumps in the North Sea
(Dual Voltage 2300-3300V / 160A)



LNG transport, eight Multi-Start pumps
(6600V / 1 x 120A + 4 x 60A)

The HRVS-DN is individually tested for:
Lloyds, Germanischer Lloyds, DNV, BV, RINA & ABS



Kazakhstan
Iron Ore Mud Pumps at 6000V / 500A (Synchronous Motors)

Standard, OEM, Options, Special Versions and Starter Sizing



Standard Version



Marine & Offshore



Multi-Motor application with fan cooling system



Narrow 80cm (31") for 4160V with Load Make Fault Break switch, Fuse base, Fuses w/wo Striker-pin arrangement



Retrofit, 4.16KV, 8BK20 existing bus-bars, 1600mm (63") Depth



Retrofit, Dual Voltage, 2300-3300V, 1500mm (59") Height

OEM Chassis Kit

IP 00 Chassis type:

- Power module
- Control module
- EPT receiver
- Control transformer
- Power supply unit (above 10 KV)

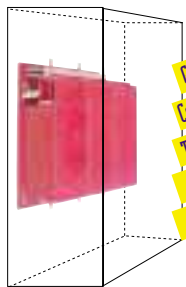

Germany
Colombia
Taiwan
Peru
Korea

Sizing The Appropriate HRUS-DN

- Type of application (Pump, Compressor, Conveyor, etc.)
- Motor Rated Power (KW or HP)
- Motor Nominal Current (A)
- Motor Nominal voltage (V)
- Motor Synchronous speed (RPM)
- Curve of motor current vs. speed or I_{st}/I_n (% or Per Unit)
- Curve of motor torque vs. speed or T_{st}/T_n and T_{max}/T_n (% or Per Unit)
- Rotor inertia $J=GD^2/4$ (Kgm²)
- Curve of load torque vs. speed (% or Per Unit)
- Load inertia $J=GD^2/4$ (Kgm²) at motor speed
- Number of starts per hour and time between starts
- Ambient temperature
- Altitude (Meters Above Sea Level)



Dual Feed, 4 Motor Multistart 6600V, 250A, with disconnect switch for each line input and motor output



Soft-starter for 3300V, 250A with incoming compartment, disconnect switch and a fuse base.

Medium voltage MCC lineup with load make fault break switch, fuses and a protection relay.



Switchgear Options

- Line Vacuum Contactor
- Bypass Vacuum Contactor
- Control Voltage: 110-220VAC, 110VDC
- Special thick paint
- MCT (Multi Cable Transit)
- Fan system - increased cooling
- Tin/Paint plated busbars (horizontal and / or vertical)
- Halogen free and fire retardant materials
- Main Switch (On-load or Off-load)
- Main Fuses (with/without striker-pin indication)
- Motor Protection Relay (MPR 6, 2000 or 3000)
- C/T's and P/T's
- Digital Power Meter (DPM-10)
- L.V. Control devices (selector switch, push buttons, indication lights, etc.)
- IP31- IP67 (NEMA 1-4X) types are available
- Metal Clad design
- 15, 25, 50 KA Design Capabilities



Single supply with two redundant soft-starters, where any starter can start any of the three fire extinguishing pumps 3.3KV, 110A



Standard medium voltage 10-15KV, 30-2000A construction. Line & bypass contactors are segregated in individual compartments for supply input and motor output.

Unique Performance

Partial Discharge Design & Test (Korona)

The HRVS-DN withstands **EN 50178** part **HD 625.1**. Each starter is fully tested for Partial Discharge (Korona) improving safety and long term reliability

EMC Design & Test (KEMA)

The HRVS-DN is EMC tested to withstand **EN 61000-6-4** and **EN 61000-6-2**.

Low Voltage Test

Innovative low voltage testing with a small 400V motor. This unique mode of operation allows fully functional performance test. Enabling Line and Bypass contactors operation as well as plant control system. (The procedure is field Initiated in minutes and includes active protection status with no need for any additional equipment.)



"Dry", No Voltage Testing

"Dry" testing allows thyristor firing, relays, indication lights and contactors to be tested without mains voltage connection.

Wireless Electronic Potential Transformer (EPT)

Advanced Electronic Potential Transformer utilizing Patent Pending "wireless" voltage measurement system.

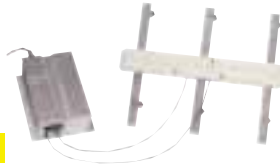

Saves: Space, Weight, Cabling, Engineering & Costs

Direct Power Factor Capacitor Connection

Power factor capacitors can be connected directly to the upstream contactor, omitting the need for additional contactor, providing stable mains (-15% + 10%) during starting.

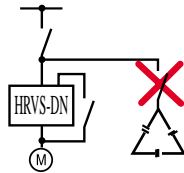

Saves: Space, Weight, Cabling, Engineering & Costs

Multi - Motor Starting

Unique Multi-Motor program allows for more than one motor to be started with the same soft starter.

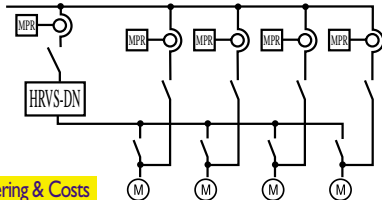

Saves: Space, Weight, Cabling, Engineering & Costs

Multi-Voltage Starters

Unique Dual-Voltage connection allows for more than one voltage level to be used with the same soft starter.

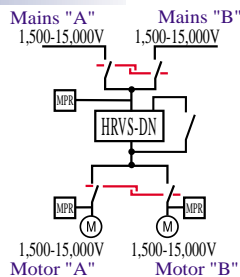

Saves: Space, Weight, Cabling, Engineering & Costs

Fiber-Optic Firing System

Unique, Patent Pending fiber-optic firing system provides complete isolation between MV and LV compartments.

Individual Thyristor Fault Indication

Unique fault indication down to the individual thyristor level

Starting from Diesel Generator

Wide 45-65Hz Auto-tracking frequency range combining special software with unique hardware arrangement (designed for Marine, Offshore and Generators operating under continuous frequency variation)



Synchronous Motor Starting

Highly sophisticated optional module allows for Synchronous motor starting.

Motor Insulation Protection

- Optional Motor Insulation Protection (Internal PCB).
- MIP 6 - Insulation protection system (Analysis and historical event recorder).



Pump and Special Load Control

Two major problems are associated with the starting and stopping of pumps (see our "Pump Application" Guide).



Over-Pressure During Starting

The sharp increase of torque towards the end of acceleration can cause high pressure and damage the pipe system. The Pump Control enables selection between three voltage ramp-up curves as well as torque curve to reduce peak torque. Current ramp is available for special loads.

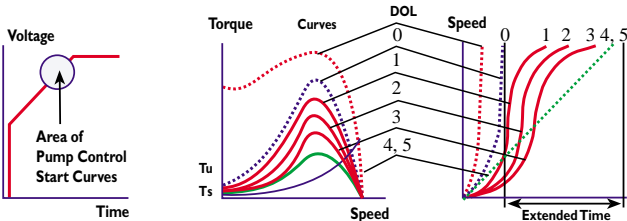

Water Hammer During Stopping

During Soft Stop, when voltage is decreasing, motor torque may fall below load torque causing abrupt stalling instead of smoothly decreasing speed to zero. This creates the Water Hammer phenomenon (resulting in a loud noise and damage to the pipe system). The Pump Control feature enables selection between three voltage ramp-down curves or torque curve to prevent stall conditions and eliminate Water Hammer.

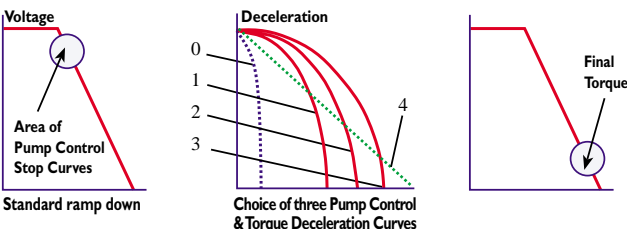

General Information

Dimensions & Weights

System Voltage	Starter Current	Motor KW	Motor HP	IP 00 (Chassis Version) Dimensions (mm) & Weight				IP 31 - 67 (NEMA 1- 3R,4X) Dimensions (mm) & Weight			IP 31 With L+BP contactors (Kg)
				W	H	D	(Kg)	W	H	D	
2300	60	200	260	660	550	470	90	900	2300	1000	500
	110	360	480	660	550	470	90	900	2300	1000	500
	200	660	880	660	550	470	90	900	2300	1000	500
	320	1,060	1,420	660	550	470	130	900	2300	1000	530
	400	1,330	1,770	660	800	490	160	900	2300	1000	570
	600	2,000	2,700	660	800	490	200	900	2300	1000	650
	800	2,660	3,600	900	1120	620	350	1100	2300	1100	1050
	1000	3,330	4,500	900	1120	620	450	1100	2300	1100	1100
3300	60	280	380	660	900	470	140	900	2300	1000	550
	110	520	700	660	900	470	140	900	2300	1000	550
	200	950	1,300	660	900	470	140	900	2300	1000	550
	320	1,530	2,050	660	900	470	140	900	2300	1000	550
	400	1,910	2,600	660	1000	470	200	900	2300	1000	650
	600	2,850	3,900	660	1000	470	250	900	2300	1000	650
	800	3,820	5,200	900	1120	620	400	1100	2300	1100	900
	1000	4,780	6,500	900	1120	620	400	1100	2300	1100	1100
4160	60	360	490	660	900	470	140	900	2300	1000	550
	110	660	880	660	900	470	140	900	2300	1000	550
	200	1,200	1,600	660	900	470	140	900	2300	1000	550
	320	1,930	2,570	660	900	470	150	900	2300	1000	560
	400	2,410	3,210	660	1000	470	180	900	2300	1000	620
	600	3,610	4,900	660	1000	470	195	900	2300	1000	650
	800	4,820	6,500	900	1120	620	450	1100	2300	1100	1050
	1000	6,030	8,200	900	1120	620	500	1100	2300	1100	1100
6600	70	670	900	900	1030	570	250	1100	2300	1100	850
	140	1,340	1,800	900	1030	570	250	1100	2300	1100	850
	250	2,390	3,200	900	1030	570	250	1100	2300	1100	850
	300	2,870	3,900	900	1120	580	300	1100	2300	1100	900
	400	3,820	5,200	900	1120	580	300	1100	2300	1100	900
	500	4,780	6,500	900	1120	620	300	1100	2300	1100	900
	700	6,740	9,100	1200	1200	713	450	1400	2300	1200	1150
	800	7,650	10,400	1200	1200	713	550	1400	2300	1200	1250
	1000	9,570	13,000	1200	1200	713	650	1400	2300	1200	1350
	1200	11,500	15,600	1200	1200	713	650	1400	2300	1400	1350
10,000	70	1,020	1,360	1136	1370	640	785	2600	2300	1200	2100
	140	2,040	2,720	1136	1370	640	785	2600	2300	1200	2100
	250	3,650	4,900	1136	1370	640	785	2600	2300	1200	2100
	300	4,300	5,900	1136	1370	640	810	2600	2300	1200	2100
	400	5,800	7,900	1136	1370	640	850	2600	2300	1200	2100
	700	10,150	13,800	1500	1700	750	1200	3500	2400	1400	2500
	800	11,600	15,800	1500	1700	750	1200	3500	2400	1400	2500
	1000	14,500	19,700	1500	1700	750	1500	3500	2400	1400	2800
1200	17,400	23,700	1500	1700	750	1500	3500	2400	1400	2800	
11,000	70	1,100	1,500	1136	1370	640	800	2600	2300	1200	2100
	140	2,200	3,000	1136	1370	640	800	2600	2300	1200	2100
	250	4,000	5,400	1136	1370	640	800	2600	2300	1200	2100
	300	4,800	6,500	1136	1370	640	830	2600	2300	1200	2100
	400	6,400	8,650	1136	1700	640	870	2600	2300	1200	2100
	700	11,200	15,200	1500	1700	750	900	3500	2400	1400	2700
	800	12,800	17,300	1500	1700	750	950	3500	2400	1400	2700
	1000	16,000	21,700	1500	1700	750	1000	3500	2400	1400	2800
1200	19,200	26,000	1500	1700	750	1000	3500	2400	1400	2800	
13,800	70	1,400	1,900	1136	1700	640	900	3000	2400	1200	2800
	140	2,800	3,800	1136	1700	640	900	3000	2400	1200	2800
	250	5,000	6,800	1136	1700	640	900	3000	2400	1200	2800
	300	6,000	8,150	1136	1700	640	950	3000	2400	1200	2800
	400	8,000	10,900	1136	1700	640	1000	3000	2400	1200	2800
	700	14,000	19,000	3000	1400	750	1150	4200	2400	1400	2900
	800	16,000	21,800	3000	1400	750	1150	4200	2400	1400	2900
	1000	20,000	27,200	3000	1400	750	1400	4200	2400	1400	3100
1200	24,000	32,700	3000	1400	750	1500	4200	2400	1400	3100	
15,000	70	1,500	2,000	1136	1900	640	950	3000	2500	1200	3150
	140	3,000	4,100	1136	1900	640	950	3000	2500	1200	3150
	250	5,400	7,400	1136	1900	640	950	3000	2500	1200	3150
	300	6,500	8,800	1136	1900	640	1000	3000	2500	1200	3200
	400	8,700	11,800	1136	1900	640	1050	3000	2500	1200	3250
	700	15,200	20,700	3000	1500	750	1300	4200	2500	1400	4100
	800	17,400	23,700	3000	1500	750	1300	4200	2500	1400	4100
	1000	21,800	29,600	3000	1500	750	1700	4200	2500	1400	4200
1200	26,150	35,500	3000	1500	750	1700	4200	2500	1400	4200	

* HP and KW ratings are for reference purpose only

* For values below 60A and above 1200A please consult factory

* For soft starters above 5000KW please consult factory

* At IP00 (chassis version) above 10KV, power supply dimension and weight are not included

* Please consult factory as dimensions may change pending certain options