

# AD Series

AD Series AC Servo Drive realizes the highest performance of your machines with Hitachi's Advanced Drive technology



# Hitachi AD Series AC Servo Drive Meets Vario from Demanding Applications with Its Full Realised by Hitachi's Advanced Motor Techno

## REALISATION OF LESS-VIBRATION, HIGH-RESPONSE, AND HIGH-PRECISION OPERATION

### Drastically Reduced Motor Cogging Torque

With Hitachi's Advanced Motor technology (patented), motor cogging torque has been reduced by approximately 65% (comparison with our previous model.)

The AD Series Servo Drive is suitable for such applications as high-precision process machine or smart conveyer system where vibration should be avoided.

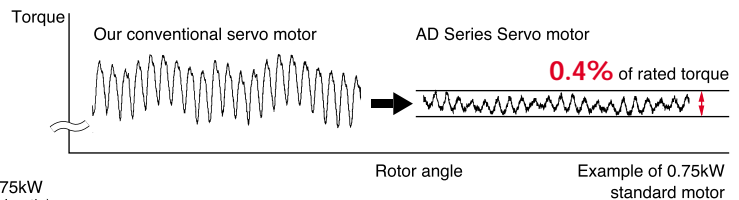

### High Response and High precision

High-precision positioning and stable rotation at low speed can be realised with 32-bit system LSI with DSP, which assures speed response frequency of 500Hz, and high-resolution 17-bits serial encoder.

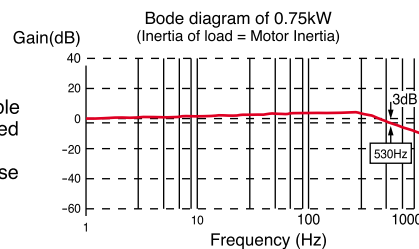

### ADA2 & ADA3 Amplifier for higher performance

Positioning time of 0.84 ms has been achieved by Hitachi's Advanced Drive Technology. Tact-time can be drastically reduced for high hit-rate positioning applications.

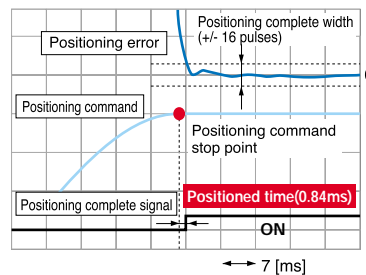

### ADA2 & ADA3 Amplifier for higher performance

High-precision control can be realised with "Minimum Position Error Control", which can reduce position error drastically.

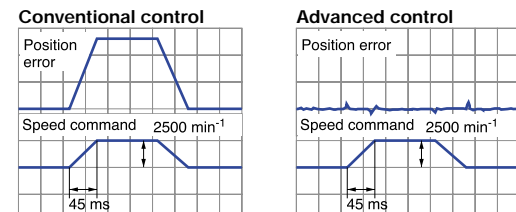

## USER FRIENDLINESS

### Configuration and Monitoring through a Personal Computer

By using configuration software AHF, which runs on Windows® operating system, parameters can be set through a personal computer, and position, speed, torque, etc of the AC servo drive can be monitored on the PC display. (Windows® is a registered trademark of Microsoft Corp. in the U.S. and other countries.)

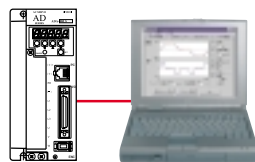

	Operational Condition
Hardware	RS232C Communication port
	more than 32MB Memory space
	more than 30MB HDD space
	more than 800x600 Display resolution
OS	Windows®95/98/Me/2000/XP
	WindowsNT®4.0

#### • Parameter setting

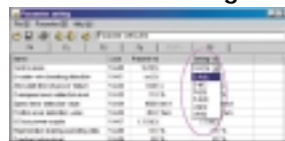

#### • Operation trace data



#### • Trial run support tool

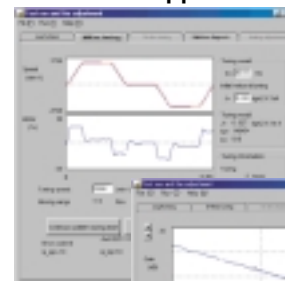

#### • Machine analysis

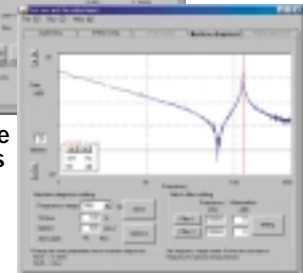

### Built-in Programmable Sequence Function (ADAX type)

Servo amplifier with Programmable Sequence Function is available (ADAX type). Single-axis positioning operation, I/O terminal control, etc are possible by programming language similar to BASIC®.

### Auto-tuning Function

Control gains can be automatically tuned to the optimum values according to each application.

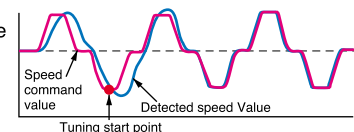

# us Requirements Feature Performance logy.

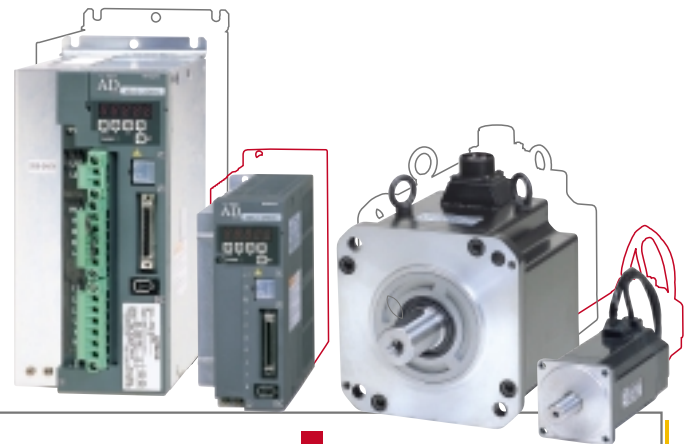

## VARIETY OF AVAILABLE SYSTEM CONFIGURATION

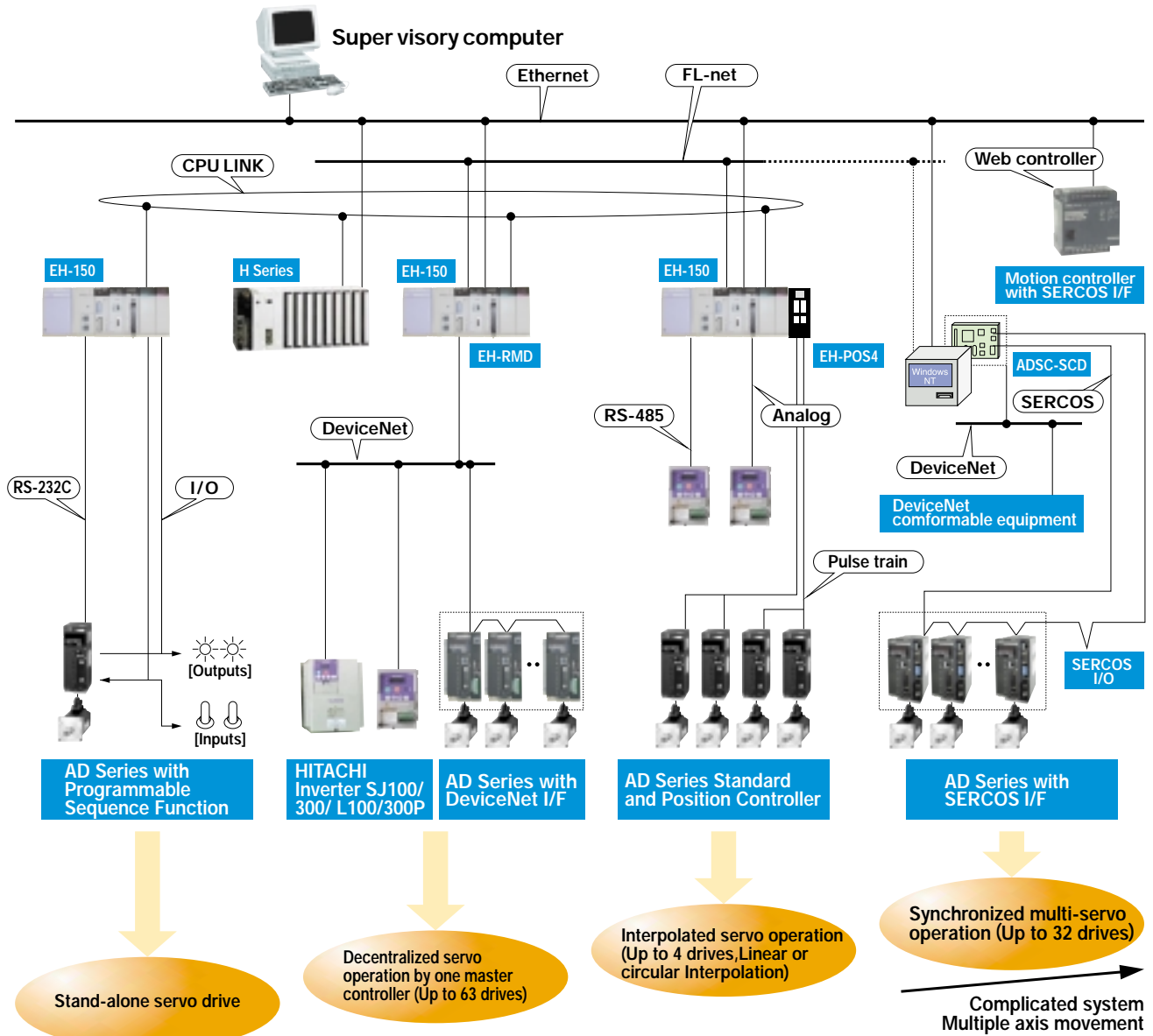

Simple system  
Single axis movement

Decentralized servo operation by one master controller (Up to 63 drives)

Interpolated servo operation (Up to 4 drives, Linear or circular Interpolation)

Synchronized multi-servo operation (Up to 32 drives)

Complicated system  
Multiple axis movement

## GLOBAL PERFORMANCE

**Network Compatibility**  
AD Series Servo Drive can communicate with controller by DeviceNet™, and SERCOS.

**Conformity to Global Standard**  
CE, UL, and c-UL approvals.



## ISO 14001 EC97J1095



Hitachi AC servo drives in this brochure are produced at the factory registered under the ISO14001 Standard for environment management system.

# AC Servo Drive with Programmable Sequence Function

## 1. Features

- Smart servo drive enables stand-alone operation!
  - Program size up to 512 steps is available.
  - Don't need any PLCs for simple drive control system.
- Compact size! Don't need any option board!
- Plenty of Input/Output ports!
  - 12 points DI/ 8 points DO/ 2 ports analog signal input(0-10V).
- 22 control commands and 11 motion commands are available!
  - Start-timing control of multi-axis is also achievable by connecting plural servo amplifiers with Input/Output ports.
- 100 points for positioning reference and 16 levels for velocity reference! (Available with non-volatile memories.)
- Human friendly programming language!
  - Easy to generate your program by a language similar to Visual Basic®.
- Powerful programming environment and debugging functions!
  - Available on Windows® 95/98/Me/2000/XP, Windows® NT4.0.
  - Single step execution, control by breakpoints, etc are available.

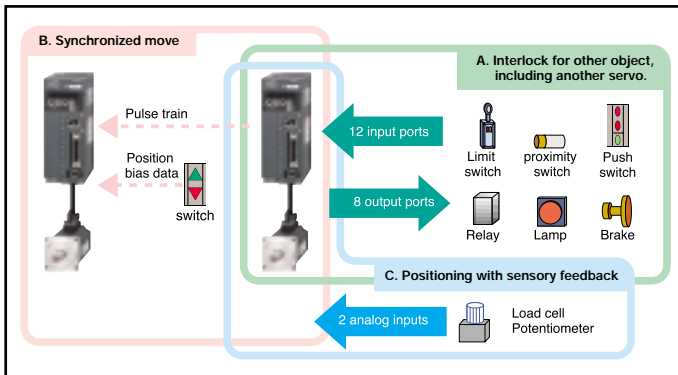

Please build up your own servo system, without any other controller.

## Specifications of Programmable Sequence Functions

Item	Specifications
Language specifications	Language type: Language similar to Visual BASIC® with additional commands for motion control.
Input device	Personal computers (Windows® 95/98/Me, Windows® NT4.0, Windows® 2000/XP)
Program size capacity	512 steps (The drive can store up to 512 steps or 6KB.)
Programming support functions	<ul style="list-style-type: none"> <li>Text input</li> <li>Display on terminal</li> <li>Program syntax check on terminal</li> <li>Program loading and all clear (PC ↔ servo drive)</li> <li>Single step execution</li> <li>Breakpoints (up to 4 points)</li> </ul>
Execution method	Interpreter method, 1.12 ms/command (Subroutine calls available, up to 8 nesting levels)
Input/output functions	Digital input: Contact signal/open-collector signal input (24V-DC internal power supply provided). servo ON, alarm reset, and general-purpose input (12 points, referred as X(0) to X(11))
Digital output	8 points (Y(0) to Y(7))
Analogue input	2 ports (XA(0) and XA(1))
Reserved words	<ul style="list-style-type: none"> <li>Variables</li> <li>Position reference: P(00) to P(99) (100 points)</li> <li>Speed reference: N(00) to N(15) (16 points)</li> <li>Torque reference: T(00) to T(15) (16 points)</li> <li>Acceleration time: ACC(0), ACC(1) (2 points)</li> <li>Deceleration time: DEC(0), DEC(1) (2 points)</li> <li>Control mode: MOD</li> <li>Control gain: KSP, KSI, KP, etc.</li> <li>Monitoring: IFB, IRF, NFB, NRF, POS, PRF, etc.</li> <li>User-defined variable: U(00) to U(15) (16 points)</li> </ul>
Commands	Instruction Mnemonic for program control command and motion control command (servo operation command)
Other	<ul style="list-style-type: none"> <li>Program storage</li> <li>Stored in the main unit's EEPROM</li> <li>Stored as source files and intermediate code files</li> </ul>
Breakpoints	Up to 4 points (set, reset, enable, or disable)

## 2. Example of application: Parts picking and placing with force control

- Servo drive with I/O control function and sensory feedback control can be performed by servo amplifier.
- Speed change by microswitch signal
  - Hold position by actual load signal level
  - On-line modification of programmed operations via manual switches
  - etc

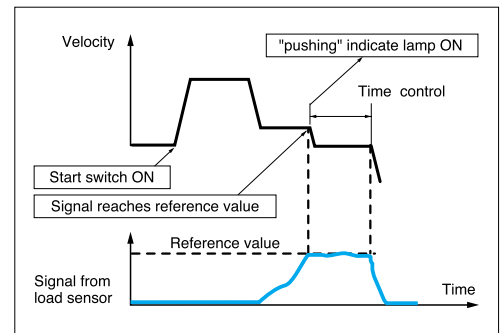
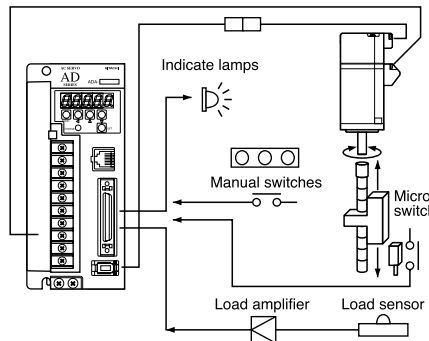

## 3. Programming Environment

Program editor is available on Windows® 95/98/Me/2000/XP, and Windows® NT4.0 personal computer system. Data transfer to/from the servo amplifier is done by RS232C communication.

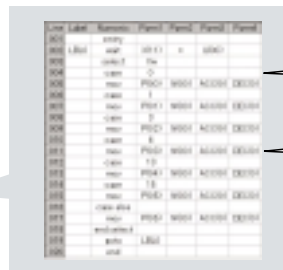
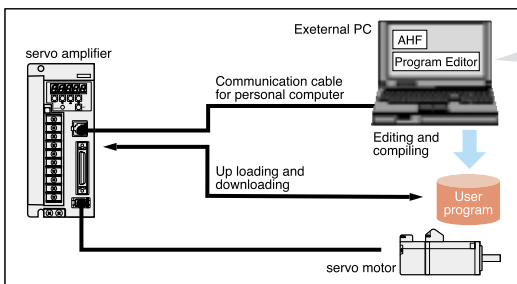

Commands are similar to Visual BASIC®. For example, 'wait', 'case', 'goto' are available.

Simple expression of motion control command. Preset variables can be edited simultaneously.

Subroutine control is also available.

Function	Process performed
Programming/editing	Program input, editing, saving, loading, and printing
Compiling and recompiling	Compiling edited program and Recompiling uploaded program
Uploading and downloading	Download/Upload the program to/from servo drive
Debugging support	Downloaded program execution, 1-step execution, breakpoint, etc.

# Nomenclature and Line-up

As for actual available set of each specification, please contact to your nearest representative.

## Model code of servo motor

**ADM A - 08 L A 1 1 1**

series name:  
AD series(motor)

Design version  
number

### TYPE

code	type of motor
A	3000min-1 Low inertia type
B	3000min-1 Pancake type
C	1500min-1 Middle inertia type
E	2000min-1 Middle inertia type
F	1000min-1 Middle inertia type
G	2000min-1 Middle inertia type(400V)

### VOLTAGE

code	Specification
M	Single phase 100V
L	Three phase 200V
S	Single phase 230V/Three phase 200V
H	Three phase 400V

### ENCODER

code	Specification
A	Incremental type, 17bit/revolution
F	Absolute type, 17bit/revolution
P	Incremental type, with reduced wiring

### MOTOR OUTPUT

code	R5	01	02	04	05	08	10	15	20	30	35	45	50	55	70
output(kW)	0.05	0.1	0.2	0.4	0.5	0.75	1	1.5	2	3	3.5	4.5	5	5.5	7

### BRAKE AND OILSEAL

code	Specification
1	without Brake, without Oilseal
2	without Brake, with Oilseal
3	with Brake(DC24V), without Oilseal
4	with Brake(DC90V), without Oilseal
5	with Brake(DC24V), with Oilseal
6	with Brake(DC90V), with Oilseal

### SHAFT END

code	Specification
1	straight, round
2	straight, with keyway
3	straight, with tapping on the end
4	straight, with keyway and tapping
5	D-shape

## Model code of servo amplifier

**ADA - 08 L S**

series name:  
AD series(amp)

### SERIES

code	Series Feature
none	Standard type
X	with Programmable SequenceFunction

### TYPE

code	Specification
none	Standard type
2	High performance type
3	High performance extended type

### VOLTAGE

code	Specification
M	Single phase 100V
L	Three phase 200V
N	Single phase 230V/Three phase 200V
H	Three phase 400V

### ENCODER

code	Specification
S	17bit/revolution serial data transmission type (adaptive to both incremental and absolute)
P	Incremental type, with reduced wiring

### AMPLIFIER CAPACITY

code	R5	01	02	04	08	10	15	20	30	35	50	70
CAPACITY (kW)	0.05	0.1	0.2	0.4	0.75	1	1.5	2	3	3.5	5	7

### OPTION





code	Specification
none	Standard type
DN2	DeviceNet
SC	SERCOS

### I/O OUTPUT POLARITY

code	Specification
none	Sink type
E	Source type

## AD Series line up

● For amplifier with Programmable Sequence Function, Type code is ADAX- and ADAX3-

Series	Servo Motor			Servo Amplifier		
	Explanation	Output	Type Code	Type Code	Explanation	
ADMA 3000min <sup>-1</sup> 	Low Inertia Type 1φ 230V/3φ 200V 17bit/rev Encoder Incremental type/Absolute type	100W	ADMA - 01SA/F	ADA3 - 01NSE	1φ 230V/3φ 200V Serial data transmission from Encoder Source type Output	
		200W	ADMA - 02SA/F	ADA3 - 02NSE		
		400W	ADMA - 04SA/F	ADA3 - 04NSE		
		750W	ADMA - 08SA/F	ADA3 - 08NSE		
		50W	ADMA - R5MA/F	ADA/ADA2 - R5MS		1φ 100V Serial data transmission from Encoder
	100W	ADMA - 01MA/F	ADA/ADA2 - 01MS			
	200W	ADMA - 02MA/F	ADA/ADA2 - 02MS			
	400W	ADMA - 04MA/F	ADA/ADA2 - 04MS			
	50W	ADMA - R5LA/F	ADA/ADA2 - R5LS	3φ 200V Serial data transmission from Encoder		
	100W	ADMA - 01LA/F	ADA/ADA2 - 01LS			
	200W	ADMA - 02LA/F	ADA/ADA2 - 02LS			
	400W	ADMA - 04LA/F	ADA/ADA2 - 04LS			
	750W	ADMA - 08LA/F	ADA/ADA2 - 08LS			
	ADMG 2000min <sup>-1</sup> 	Middle Inertia Type 3φ 400V 8192p/rev Incremental Encoder Type (with reduced wiring)	1kW	ADMA - 10LA/F	ADA/ADA2 - 10LS	3φ 400V, Incremental Encoder Type (with reduced wiring) Source type Output
			1.5kW	ADMA - 15LA/F	ADA/ADA2 - 15LS	
2kW			ADMA - 20LA/F	ADA/ADA2 - 20LS		
3kW			ADMA - 30LA/F	ADA/ADA2 - 30LS		
5kW			ADMA - 50LA/F	ADA/ADA2 - 50LS		
0.5kW			ADMG - 05HP	ADA3 - 15HPE	ADA3 - 15HPE	
1kW			ADMG - 10HP	ADA3 - 15HPE		
ADMB 3000min <sup>-1</sup> 	Pancake Type 1φ 100V 17bit/rev Encoder Incremental type/Absolute type	200W	ADMB - 02MA/F	ADA/ADA2 - 02MS	1φ 100V Serial data transmission from Encoder	
		400W	ADMB - 04MA/F	ADA/ADA2 - 04MS		
	Pancake Type 3φ 200V 17bit/rev Encoder Incremental type/Absolute type	200W	ADMB - 02LA/F	ADA/ADA2 - 02LS	3φ 200V Serial data transmission from Encoder	
		400W	ADMB - 04LA/F	ADA/ADA2 - 04LS		
		750W	ADMB - 08LA/F	ADA/ADA2 - 08LS		
ADMC 1500min <sup>-1</sup> 	Middle Inertia Type 3φ 200V 17bit/rev Encoder Incremental type/Absolute type	1kW	ADMC - 10LA/F	ADA/ADA2 - 10LS	3φ 200V Serial data transmission from Encoder	
		1.5kW	ADMC - 15LA/F	ADA/ADA2 - 15LS		
		2kW	ADMC - 20LA/F	ADA/ADA2 - 20LS		
		2.9kW	ADMC - 30LA/F	ADA/ADA2 - 30LS		
		4.5kW	ADMC - 45LA/F	ADA/ADA2 - 50LS		
		400W	ADMC - 04LA/F	ADA/ADA2 - 04LS		ADA/ADA2 - 04LS
750W	ADMC - 08LA/F	ADA/ADA2 - 08LS				

# Specifications of Servo Motors

## Basic Specifications

Time Rating	Continuous
Ambient Temperature	0 to +40
Ambient Humidity	20 to 90%RH(without condensation)

Durability of vibration	24.5m/s <sup>2</sup> (2.5G),XYZ direction each for 2Hr, from 10Hz to120Hz
Mounting	Flange mounting

## 1.Low inertia type (single phase 230V ) ADMA and Middle inertia type (three phase 400V) ADMG

items	unit	specification											
Input voltage to the amplifier		single phase 230V/three phase 200V				three phase 400V							
Type code		ADMA-				ADMG-							
		01S	02S	04S	08S	05H	10H	15H	20H	35H	45H	55H	70H
Type code of Relevant Servo Amplifier		ADA3-				ADA3-							
		01NSE	02NSE	04NSE	08NSE	15HPE			35HPE		70HPE		
Rated output	kW	0.1	0.2	0.4	0.75	0.5	1.0	1.5	2.0	3.5	4.5	5.5	7.0
Rated torque	N·m	0.32	0.64	1.27	2.39	2.4	5	7.5	9.55	16.7	21.5	26.3	33.4
Instantaneous peak torque	N·m	0.96	1.91	3.82	7.16	9	18.5	20	30	45.5	70	72	86
Rated speed	min-1	3000				2000							
Max speed	min-1	4500				3000							
Moment of Inertia Jm	kg.m <sup>2</sup>	0.023	0.12	0.22	0.62	1.84	5.40	8.80	11.8	37.9	46.5	113.5	185
(upper:without Brake lower:with Brake)	x10-4	0.032	0.16	0.25	0.71	2.18	5.85	9.30	12.3	41.3	49.9	137.5	209
Preferable Load Inertia		up to 30 times Motor Inertia				up to 5 times Motor Inertia							
Rated Power Rate (without Brake)	kW/sec	44.0	33.8	73.3	92.1	31.0	46.0	64.0	77.0	74.0	99.0	61.0	60.0
Position/SpeedDetector *means optional		17 bits/rev Incremental encoder *17bits/rev Absolute encoder (serial data transmission)				4096ppr				Incremental encoder 8192ppr			
Protection		IP55 ( excluding connectors and the part passed through by the shaft )				IP67 ( excluding the part passed through by the shaft )							

## Specifications of the Brake

Type		Electromechanical brake, release when activated.											
Supply voltage		DC24V,+10%,-10%				DC24V,+10%,-10%							
Static friction torque(minimum)	N·m	0.34	1.5	1.5	2.6	2.9	9.8	9.0	12	32	32	90	90
Rated current(20°C)	A	0.27	0.27	0.27	0.38	0.33	0.83	0.87	1.0	1.4	1.4	1.3	1.3
Coil resistance(20°C)	ohm	89	89	89	64	72	28	28	23	17	17	18	18
Power consumption(20°C)	W	6.5	6.5	6.5	9.0	8.0	20	21	25	34	34	32	32
Dragging time(maximum)	ms	25	60	60	50	30	100	100	100	150	150	300	300
Release time(maximum)	ms	20	10	10	15	20	30	30	30	40	40	140	140

note1. This brake is specified as holding the shaft statically, not as stopping the rotating shaft.

## Torque Characteristics

### Single phase 230V

ADMA-01S

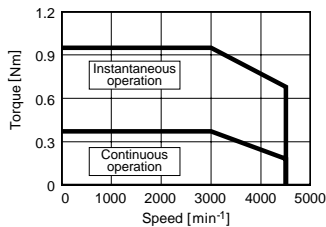

ADMA-02S

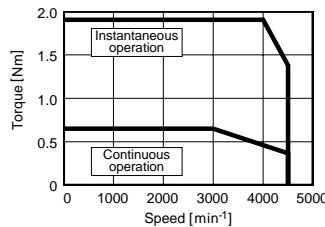

ADMA-04S

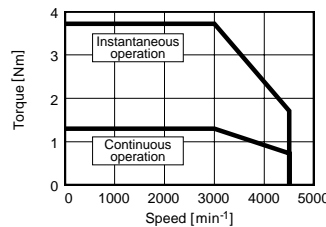

ADMA-08S

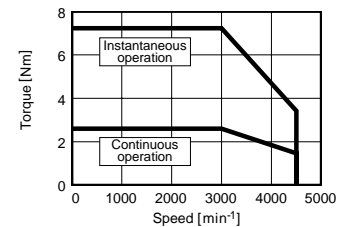

### Three phase 400V

ADMG-05H

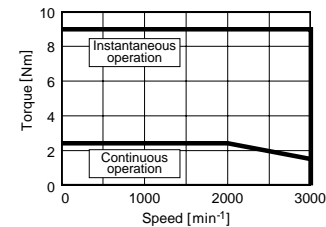

ADMG-10H

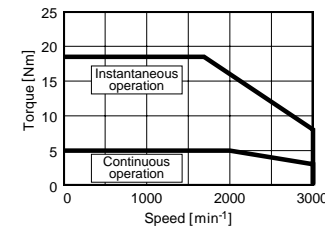

ADMG-15H

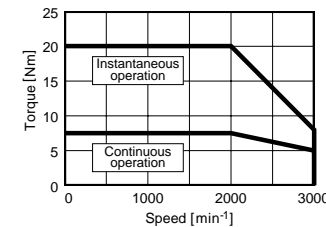

ADMG-20H

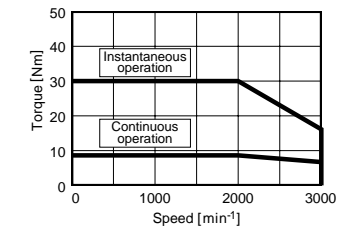

ADMG-35H

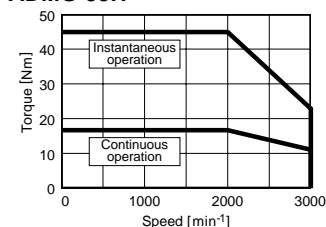

ADMG-45H

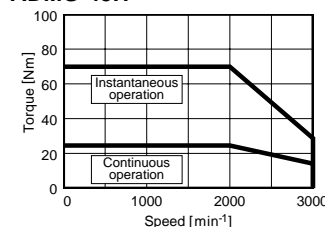

ADMG-55H

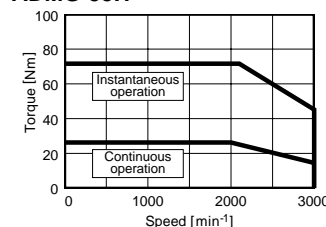

ADMG-70H

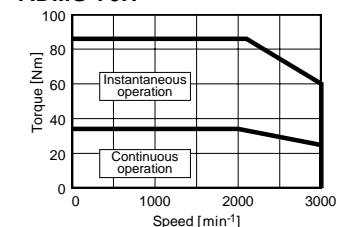

note1) These characteristics are guaranteed when the motor is driven by the relevant servo amplifier and the input voltage to the amplifier is more than AC 230V(ADMA-\*\*S) or AC400V(ADMG-\*\*H).

note2) These are typical values, under the condition of cold amature windings.

note3) The values in continuous operation is guaranteed when the motor is correctly mounted on to the aluminium mounting base functioning as the cooling plate with the dimensions noted below.

ADMA-01S : 150x150x6 ADMA-02S : 250x250x6 ADMA-04S : 250x250x12 ADMA-08S : 300x300x12 ADMG-05H: 305x305x12 ADMG-10H,15H : 400x400x20

ADMG-20H,35H,45H : 470x470x20 ADMG-55H,70H : 540x540x20

# Specifications of Servo Motors

## 2.Low inertia type( single phase 100V and three phase 200V ) ADMA

items	unit	specification													
Input voltage to the amplifier		single phase 100V							three phase 200V						
Type code		ADMA-													
Type code of Relevant Servo Amplifier		R5M	01M	02M	04M	R5L	01 L	02 L	04L	08L	10L	15L	20L	30L	50L
		ADA-, ADA2-													
		R5MS	01MS	02MS	04MS	R5LS	01LS	02LS	04LS	08LS	10LS	15LS	20LS	30LS	50LS
Rated output	kW	0.05	0.1	0.2	0.4	0.05	0.1	0.2	0.4	0.75	1.0	1.5	2.0	3.0	5.0
Rated torque	N·m	0.16	0.32	0.64	1.27	0.16	0.32	0.64	1.27	2.39	3.18	4.77	6.37	9.55	15.9
Instantaneous peak torque	N·m	0.48	0.96	1.91	3.82	0.48	0.96	1.91	3.82	7.16	9.55	14.3	19.1	28.6	47.7
Rated speed	min-1	3000							3000						
Max speed	min-1	4500							5000						
Moment of Inertia Jm	kg.m2	0.014	0.023	0.12	0.22	0.014	0.023	0.12	0.22	0.62	1.24	1.71	2.05	5.36	8.52
(upper:without Brake lower:with Brake)	x10-4	0.023	0.032	0.16	0.25	0.023	0.032	0.16	0.25	0.71	1.49	1.95	2.27	6.45	9.62
Preferable Load Inertia		up to 30 times Motor Inertia							up to 5 times Motor Inertia						
Rated Power Rate (without Brake)	kW/sec	18.1	44.0	33.8	73.3	18.1	44.0	33.8	73.3	92.1	81.6	133	198	170	297
Position/SpeedDetector		17 bits/rev Incremental encoder (serial data transmission), 17 bits/rev absolute encoder (serial data transmission)													
Protection		IP55 ( excluding connectors and the part passed through by the shaft )													

## Specifications of the Brake

Type		Electromechanical brake, release when activated.													
Supply voltage		DC24V,+10%,-10%													
Static friction torque(minimum)	N·m	0.34	0.34	1.5	1.5	0.34	0.34	1.5	1.5	2.6	3.5	7.0	7.0	17	17
Rated current(20°C)	A	0.27	0.27	0.27	0.27	0.27	0.27	0.27	0.27	0.38	0.58	0.71	0.71	1.1	1.1
Coil resistance(20°C)	ohm	89	89	89	89	89	89	89	89	64	41	34	34	21	21
Power consumption(20°C)	W	6.5	6.5	6.5	6.5	6.5	6.5	6.5	6.5	9	14	17	17	27	27
Dragging time(maximum)	ms	25	25	60	60	25	25	60	60	50	60	90	90	95	95
Release time(maximum)	ms	20	20	10	10	20	20	10	10	15	20	20	20	20	20

note1. This brake is specified as holding the shaft statically, not as stopping the rotating shaft.

note2. Brakes with the supply voltage of DC90V is also available for motors operated with the supply of single phase 100V or three phase 200V.

## Torque Characteristics

### Three phase 200V and Single phase 100V ( Broken line for Single phase 100V )

ADMA-R5L,R5M

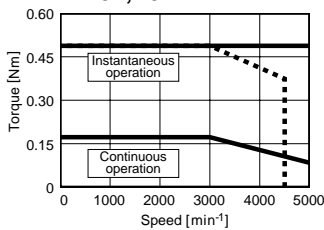

ADMA-01L,01M

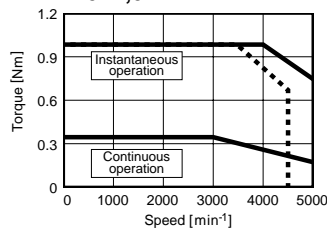

ADMA-02L,02M

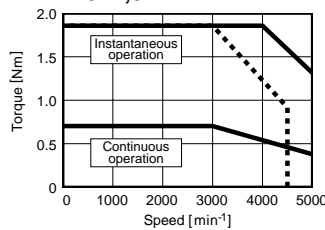

ADMA-04L,04M

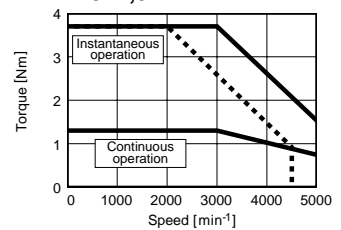

ADMA-08L

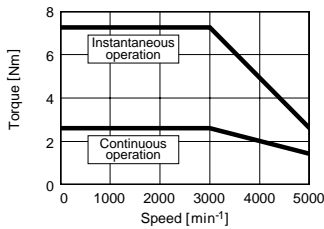

ADMA-10L

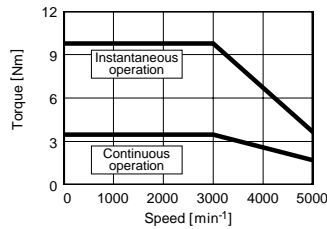

ADMA-15L

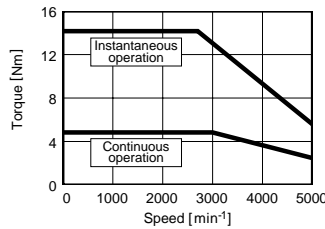

ADMA-20L

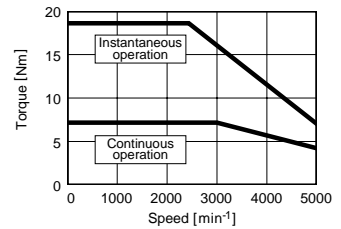

ADMA-30L

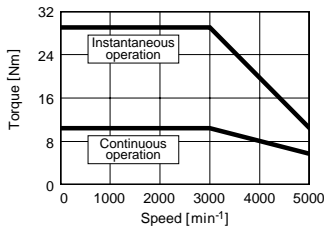

ADMA-50L

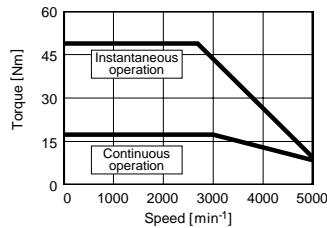

note1) These characteristics are guaranteed when the motor is driven by the relevant servo amplifier and the input voltage to the amplifier is more than AC200V (ADMA-\*\*L) or AC100V (ADMA-\*\*M).

note2) These are typical values, under the condition of cold armature windings.

note3) The values in continuous operation is guaranteed when the motor is correctly mounted on to the aluminium mounting base functioning as the cooling plate with the dimensions noted below.

ADMA-R5L,R5M,01L,01M : 150x150x6 ADMA-02L,02M : 250x250x6 ADMA-04L,04M : 250x250x12 ADMA-08L : 300x300x12 ADMA-10L : 250x250x12  
ADMA-15L,20L,30L : 300x300x20 ADMA-50L : 400x400x20

# Specifications of Servo Motors

## 3. Pancake type (single phase 100V and three phase 200V) ADMB and Middle inertia type (three phase 200V) ADMC

items	unit	specification												
Input voltage to the amplifier		single phase 100V						three phase 200V						
Type code		ADMB-						ADMC-						
Type code of Relevant Servo Amplifier		02M	04M	02L	04L	08L	10L	04L	08L	10L	15L	20L	30L	45L
Rated output	kW	0.2	0.4	0.2	0.4	0.75	1.0	0.4	0.75	1.0	1.5	2.0	2.9	4.5
Rated torque	N·m	0.64	1.27	0.64	1.27	2.39	3.18	2.55	4.77	6.37	9.55	12.7	18.5	28.6
Instantaneous peak torque	N·m	1.91	3.82	1.91	3.82	7.16	9.55	7.64	14.3	19.1	28.6	38.2	50.0	85.9
Rated speed	min-1	3000			3000			1500						
Max speed	min-1	4500			5000			2000						
Moment of Inertia Jm	kg.m2	0.19	0.32	0.19	0.32	1.78	2.26	1.24	1.71	2.05	5.36	7.68	66.3	97.6
(upper: without Brake lower: with Brake)	x10-4	0.28	0.41	0.28	0.41	2.87	3.35	1.49	1.95	2.27	6.45	8.77	76.6	110
Preferable Load Inertia		up to 20 times Motor Inertia						up to 5 times Motor Inertia						
Rated Power Rate (without Brake)	kW/sec	21.6	50.4	21.6	50.4	32.1	45.3	54.2	133	198	170	210	51.4	83.8
Position/Speed Detector		17 bits/rev Incremental encoder, 17 bits/rev absolute encoder (serial data transmission)												
Protection		IP55 (excluding connectors and the part passed through by the shaft)												

## Specifications of the Brake

Type	Electromechanical brake, Release when activated.													
Supply voltage	DC24V, +10%, -10%													
Static friction torque (minimum)	N·m	1.4	1.4	1.4	1.4	3.4	3.4	3.5	7	7	17	17	43.1	43.1
Rated current (20°C)	A	0.38	0.38	0.4	0.4	0.6	0.6	0.6	0.7	0.7	1.1	1.1	0.77	0.77
Coil resistance (20°C)	ohm	64	64	64	64	40	40	41	34	34	21	21	31.1	31.1
Power consumption (20°C)	W	9	9	9	9	14.5	14.5	14	17	17	27	27	18.5	18.5
Dragging time (maximum)	ms	50	50	50	50	70	70	60	90	90	95	95	170	170
Release time (maximum)	ms	15	15	15	15	25	25	20	20	20	20	20	80	80

note1. This brake is specified as holding the shaft statically, not as stopping the rotating shaft.

note2. Brakes with the supply voltage of DC90V is also available for motors operated with the supply of single phase 100V or three phase 200V.

## Torque Characteristics

### Three phase 200V and Single phase 100V (Broken line for Single phase 100V)

ADMB-02L,02M

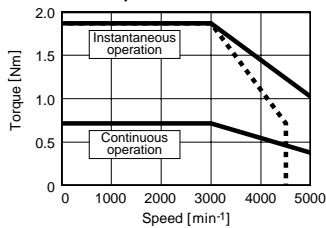

ADMB-04L,04M

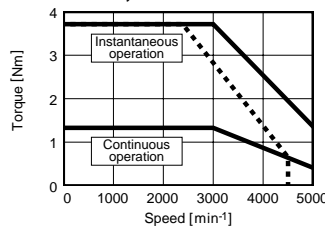

ADMB-08L

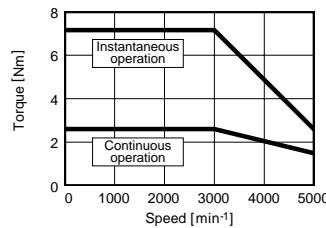

ADMB-10L

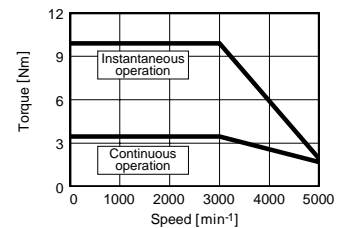

ADMC-04L

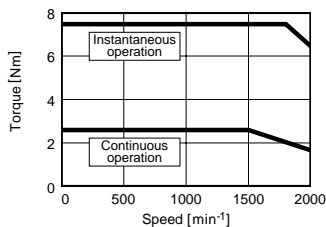

ADMC-08L

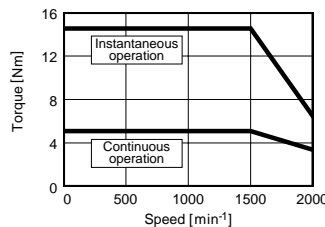

ADMC-10L

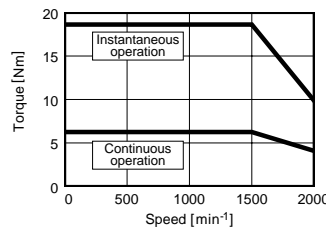

ADMC-15L

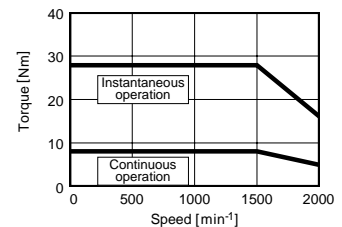

ADMC-20L

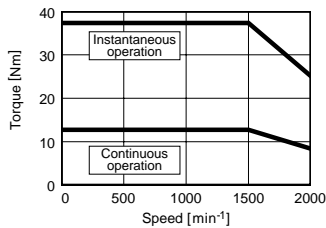

ADMC-30L

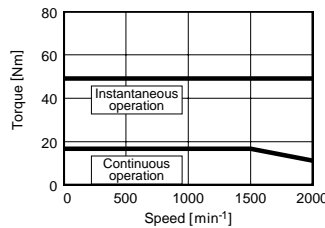

ADMC-45L

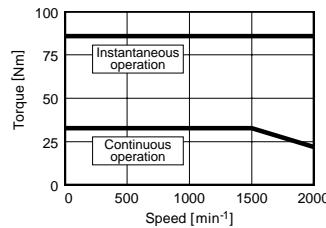

note1) These characteristics are guaranteed when the motor is driven by the relevant servo amplifier and the input voltage to the amplifier is more than AC200V (ADMB-\*\*L,ADMC-\*\*L) or AC100V (ADMB-\*\*M).

note2) These are typical values, under the condition of cold amature windings.

note3) The values in continuous operation is guaranteed when the motor is correctly mounted on to the aluminium mounting base functioning as the cooling plate with the dimensions noted below.

ADMB-02L,02M : 250x250x6 ADMB-04L,04M : 250x250x12 ADMB-08L,10L : 300x300x12 ADMC-04L : 250x250x12 ADMC-08L,10L,15L,20L : 300x300x20

ADMC-30L,45L : 550x550x30 iron plate

# Dimensions: Servo Motor

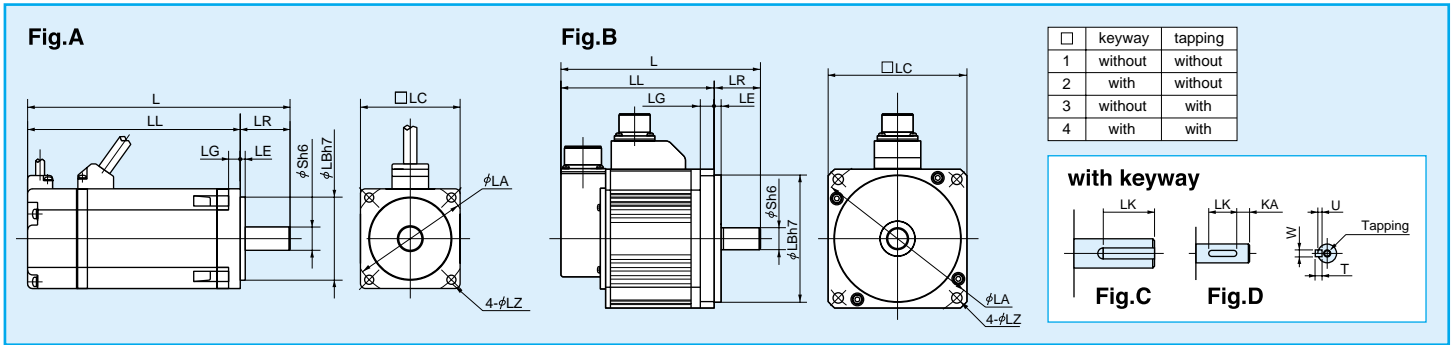

=L, M, or S/ =any number from 1 to 4/for Motors with Brakes, last letter is 3(DC24V)/4(DC90V)

Model	output	L	LL	LR	LE	LG	LC	LA	LZ	S	LB	T	U	W	LK	Tapping size	KA	Fig.	weight
ADMA-R5 A1 1	50W	104	78.5	25	2.5	5	40	46	4.5	8	30	3	1.8	3	14	M2.5 × 5	-	A	0.4
ADMA-R5 A1 3/4		139	114																0.65
ADMA-01 A1 1		122	96.5																0.55
ADMA-01 A1 3/4	100W	157	132	30	3	7	60	70	5.5	14	50	5	3	5	20	M5 × 8	-	C	0.8
ADMA-02 A1 1		130	100																1.1
ADMA-02 A1 3/4		168	138																1.7
ADMA-04 A1 1	200W	158	128	40	3	8	75	90	6.6	19	70	6	3.5	6	22	M5 × 8	-	C	1.6
ADMA-04 A1 3/4		196	166																2.2
ADMA-08 A1 1		183	143																3.1
ADMA-08 A1 3/4	750W	220	180	45	3	10	90	100	7	24	80	7	4	8	32	M8 × 16	-	B	3.9
ADMA-10LA1 1		202	157																4
ADMA-10LA1 3/4		242	197																5.2
ADMA-15LA1 1	1kW	232	187	63	6	12	120	145	9	28	110	7	4	8	50	M8 × 16	-	C	5.2
ADMA-15LA1 3/4		278	233																6.6
ADMA-20LA1 1		252	207																6.1
ADMA-20LA1 3/4	2kW	298	253	79	3.2	18	180	200	13.5	35	114.3	8	5	10	60	M12 × 12	-	B	7.5
ADMA-30LA1 1		277	214																12
ADMA-30LA1 3/4		323	260																14.1
ADMA-50LA1 1	3kW	353	290	79	4	19	220	235	13.5	55	200	10	6	16	67	M10 × 25	3	D	16.8
ADMA-50LA1 3/4		399	336																18.8

For absolute encoder, L and LL increase 16mm(50-750W), 8mm(1-2kW, 3-5kW with Brake), 13mm(3-5kW w/o Brake)

Model	output	L	LL	LR	LE	LG	LC	LA	LZ	S	LB	T	U	W	LK	Tapping size	KA	Fig.	weight
ADMB-02 A1 1	200W	125	95	30	3	8	75	90	6.6	14	70	5	3	5	20	M5 × 8	-	A	1.9
ADMB-02 A1 3/4		157	127																2.3
ADMB-04 A1 1		141	111																2.4
ADMB-04 A1 3/4	400W	173	143	40	6	12	120	145	9	19	110	6	3.5	6	22	M5 × 8	-	B	2.8
ADMB-08LA1 1		173	133																7.5
ADMB-08LA1 3/4		210	170																9.6
ADMB-10LA1 1	750W	183	143	79	4	19	220	235	13.5	35	114.3	8	5	10	60	M12 × 12	-	C	8.1
ADMB-10LA1 3/4		220	180																10.2

For absolute encoder, L and LL increase 16mm(200-400W), 8mm(750W-1kW with Brake), 13mm(750W-1kW w/o Brake)

Model	output	L	LL	LR	LE	LG	LC	LA	LZ	S	LB	T	U	W	LK	Tapping size	KA	Fig.	weight
ADMC-04LA1 1	400W	202	157	45	3	10	90	100	7	24	80	7	4	8	32	M8 × 16	-	B	4
ADMC-04LA1 3/4		242	197																5.2
ADMC-08LA1 1		232	187																6.6
ADMC-08LA1 3/4	750W	278	233	63	6	12	120	145	9	28	110	7	4	8	50	M8 × 16	-	C	6.1
ADMC-10LA1 1		252	207																7.5
ADMC-10LA1 3/4		298	253																12
ADMC-15LA1 1	1kW	277	214	79	3.2	18	180	200	13.5	35	114.3	8	5	10	60	M12 × 12	-	B	14.1
ADMC-15LA1 3/4		323	260																15.6
ADMC-20LA1 1		338	275																17.7
ADMC-20LA1 3/4	2kW	384	321	79	4	19	220	235	13.5	55	200	10	6	16	67	M10 × 25	3	D	18.5
ADMC-30LA1 1		289	210																24
ADMC-30LA1 3/4		327	248																26.6
ADMC-45LA1 1	2.9kW	337	258	79	4	19	220	235	13.5	55	200	10	6	16	67	M10 × 25	3	D	26.6
ADMC-45LA1 3/4		375	296																32

For absolute encoder, L and LL increase 8mm(400W-1kW), 8mm(1.5-2kW with Brake), 13mm(1.5-2kW w/o Brake)

Model	output	L	LL	LR	LE	LG	LC	LA	LZ	S	LB	T	U	W	LK	Tapping size	KA	Fig.	weight
ADMG-05HP142	500kW	228	193	35	3	8	86	100	6.6	16	80	5	3	5	25	M5 × 12	2	B	3.0
ADMG-05HP145		263	228																4.2
ADMG-10HP142	1kW	241	196	45	3	10	100	115	9	22	95	6	3.5	6	32	M6 × 20	3	B	5.4
ADMG-10HP145		276	231																6.8
ADMG-15HP142	1.5kW	224	169	55	4	12	130	145	9	22	110	6	3.5	6	42	M6 × 20	3	B	7.8
ADMG-15HP145		260	205																9.4
ADMG-20HP142	2kW	242	187	65	3	16	180	200	13.5	35	114.3	8	5	10	50	M8 × 25	3	B	9.8
ADMG-20HP145		282	227																11.6
ADMG-35HP142	3.5kW	268	203	79	4	19	220	235	13.5	55	200	10	6	16	67	M10 × 25	3	D	17.7
ADMG-35HP145		318	253																23.1
ADMG-45HP142	4.5kW	283	218	79	4	19	220	235	13.5	55	200	10	6	16	67	M10 × 25	3	D	21.7
ADMG-45HP145		333	268																27.1
ADMG-55HP142	5.5kW	331	252	79	4	19	220	235	13.5	55	200	10	6	16	67	M10 × 25	3	D	34.8
ADMG-55HP145		388	309																45.5
ADMG-70HP142	7kW	389	310	79	4	19	220	235	13.5	55	200	10	6	16	67	M10 × 25	3	D	52.8
ADMG-70HP145		447	368																63.5

# Specifications of Servo Amplifiers

## Basic Specifications

Ambient temperature/ storage temperature (Note 1)	0 to +55 /-10 to +70
Humidity	20 to 90%RH or less (without condensation)
Vibration (Note 2)	5.9 m/s <sup>2</sup> (0.6G), 10 to 55 Hz
Installation location	1000m or less above the sea, indoor place (free from corrosive gas and dust)
Protective structure (Note 3)	Open type IP00
Control system	Sine-wave pulse width modulation PWM system
Control mode	Position control/speed control/torque control
Built-in operator	5-digit number display unit, key input x 5
External operator	Windows® 95/98/Me, Windows® NT/2000/XP PC connectable (using the RS-232C port)
Encoder monitor signal output	Phase A, B signal output : Line driver signal output (output resolution adjustable) Phase Z signal output : Line driver signal output / open collector signal output
Monitor output	2ch,0 to 3V Voltage output, Speed detection value, Torque command, etc(selectable)
Speed command/limitation input	Analog input: 0 to ± 10 V/Maximum speed (gain adjustable)
Torque command/limitation input	Analog input: 0 to ± 10 V/Maximum torque (gain adjustable)

## single phase 230V/three phase 200V, three phase 400V

Model code : ADA3-,ADAX3-	01NSE	02NSE	04NSE	08NSE	15HPE			35HPE		70HPE		
Applicable motor capacity (kW)	0.1	0.2	0.4	0.75	0.5	1.0	1.5	2.0	3.5	4.5	5.5	7.0
Input power supply capacity(kVA)	0.4	0.75	1.2	2.3	1.2	1.8	2.5	3.5	5.6	6.8	8.3	11
Input power supply (main circuit)	1x220 to 230V/3x200 to 230V+10%, -15%, 50/60 Hz ± 5%				3x380 to 480V +10%, -15% 50/60 Hz ± 5%							
Input control power supply	1x200 to 230V +10%, -15% 50/60 Hz ± 5%				1x200 to 240V +10%, -15% 50/60 Hz ± 5%							
Rated speed (min <sup>-1</sup> )	3000				2000							
Maximum speed (min <sup>-1</sup> )	4500				3000							
Maximum torque (Ratio to the rated torque)	300%				250%-380% (see motor specification for detail)							
Position/speed feedback	17 bits/rotation Incremental encoder (standard) 17 bits/rotation Absolute encoder (option)				Incremental encoder (reduced wiring type)							
Speed control range	1:4500				1:3000							
Position command input	Line driver signal (2M pulses/s or less) Selectable from 1)-3) 1) Phase difference pulse input (Maximum input frequency is 1/4 of the value above noted) 2) Forward/reverse run direction pulse input 3) Command pulse + code input											
Input signal	Contact signal (available for both sink/source type) : Servo ON, Alarm reset,Control mode switch, Torque limit, Forward overtravel, Reverse overtravel,Multistage speed 1/exchange electrical gear, Multistage speed 2/ absolute encoder clear(Note4),Proportional control/exchange gains, Zero speed clamp/external trip signal,Homing limit switch, Homing, Pulse train input enable/forward command,Position error clear/reverse command											
Output signal	Source type output : Servo ready, Alarm, Positioning complete, Up to speed/alarm code 1, Zero speed detection, Brake release , Torque limiting/alarm code 2, Overload notice/alarm code 3											
Regenerative braking circuit	Built-in type (Braking resistor not included for 01NSE,02NSE)											
Dynamic brake	Actuated at Servo OFF, Trip, or Power OFF (operating condition selectable)											
Protective function	Overcurrent, overload, braking resistor overload, main circuit overvoltage, memory error, CPU error, main circuit undervoltage, CT error, ground fault detection at servo ON,control circuit undervoltage, external trip signal, power module error, encoder error, position deviation error, speed deviation error, overspeed error, driving range error, position monitoring timeout error, overtravel error, abnormal temperature, absolute encoder error, position data error, absolute encoder fault, motor power unmatch											
Estimated weight (kg)	0.8	0.8	1.4	1.9	1.9			4.6		7.7		

## single phase 100V, three phase 200V

Model code:ADA-,ADAX-, ADA2-	R5MS	01MS	02MS	04MS	R5LS	01LS	02LS	04LS	08LS	10LS	15LS	20LS	30LS	50LS
Applicable motor capacity (kW)	0.05	0.1	0.2	0.4	0.05	0.1	0.2	0.4	0.75	1	1.5	2	3	5
Input power supply capacity(kVA)	0.3	0.4	0.5	1	0.3	0.3	0.5	0.9	1.3	1.8	2.5	3.5	4.8	7.5
Input power supply(main circuit)	1x100 to 115V +10%, -15%, 50/60Hz ± 5%				3x200 to 230V +10%, -15% 50/60 Hz ± 5%									
Input control power supply	1x200 to 230V +10%, -15% 50/60 Hz ± 5%				1x200 to 230V +10%, -15% 50/60 Hz ± 5%									
Rated speed (min <sup>-1</sup> ) (Note5)	3000				3000									
Maximum speed (min <sup>-1</sup> ) (Note5)	4500				5000									
Maximum torque (Ratio to the rated torque)	300%													
Position/speed feedback	17 bits / rotation Incremental encoder (standard) 17 bits / rotation Absolute encoder (option)													
Speed control range	1:4500				1:5000									
Position command input	Line driver signal (500k pulses/s or less) / open collector signal (200 k pulses / s or less) input 1) Phase difference pulse input (Maximum input frequency is 1/4 of the value above noted) 2) Forward/reverse run direction pulse input 3) Command pulse + sign code input													
Input signal	Contact signal/open collector signal inputs: Servo ON, Alarm reset, Control mode switch, Torque limit, Forward overtravel, Reverse overtravel,Multistage speed 1, Multistage speed 2, Proportional control/exchange gains, Zero speed clamp, Homing limit switch, Homing, Pulse train input enable/forward command, Position error clear/reverse command													
Output signal	Open collector signal output/Servo ready, Alarm, Positioning complete, Up to speed, Zero speed detection, Brake release (servo ON answer), Torque limiting, Overload, Alarm code 1 ~ 3 (ADA2 only)													
Regenerative braking circuit	Built-in type (Braking resistor not included for R5MS, 01MS, R5LS, 01LS, 02LS)													
Dynamic brake	Actuated at Servo OFF, Trip, or Power OFF (operating condition selectable)													
Protective function	Overcurrent, overload, braking resistor overload, main power overvoltage, memory error, CPU error, main power undervoltage, CT error, ground fault, control power undervoltage, power module error, encoder error, position error, speed error, overspeed error, driving range error, position monitoring timeout error, overtravel error, abnormal temperature, absolute encoder error, absolute encoder battery alarm/error, absolute encoder counter overflow, motor power unmatch													
Estimated weight (kg)	0.8	0.8	1	1.4	0.8	0.8	0.8	1	1.4	1.9	1.9	4.6	4.6	7.7

Note 1: The storage temperature is the short-term temperature during transport.

Note 2: The testing method of JIS C0040 is applied.

Note 3: The protective structure conforms to JEM1030.

Note 4: In case of absolute encoder.

Note 5: In case of ADMA or ADMB.

# Connection diagram

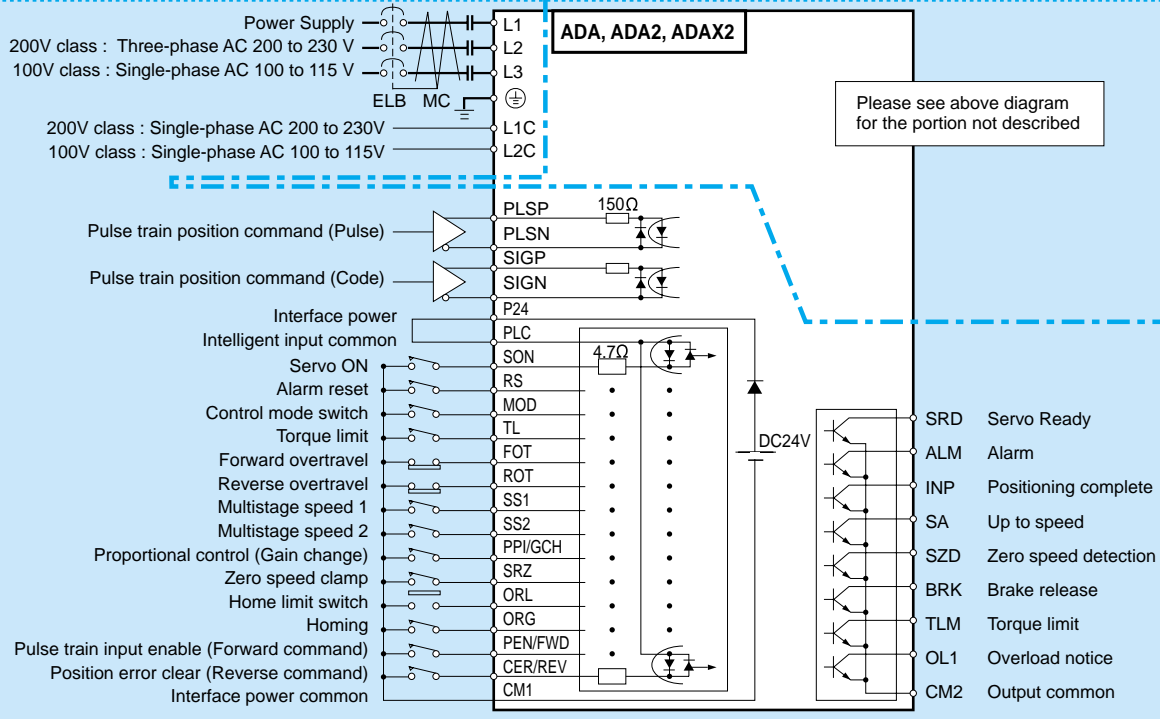
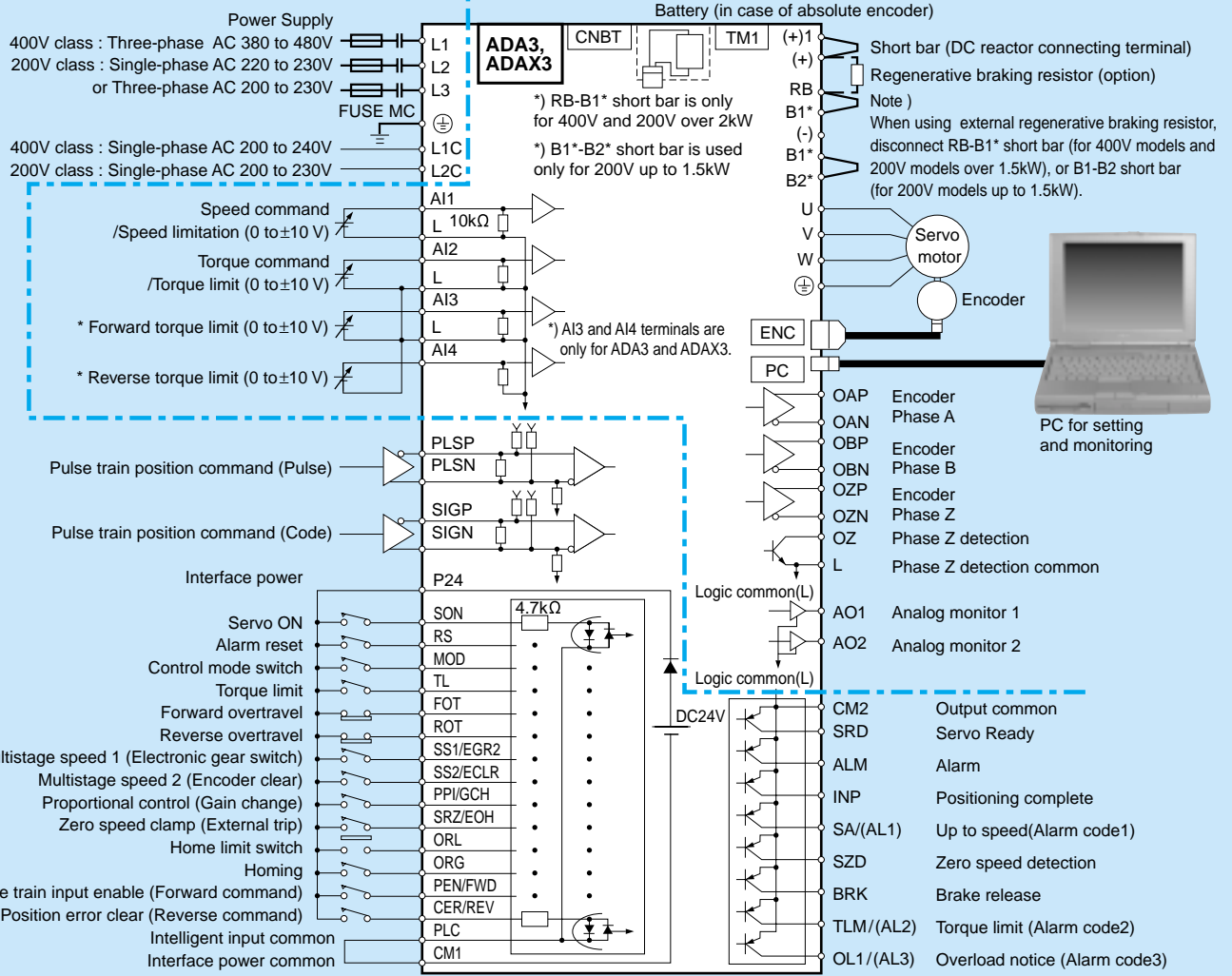

# Dimensions: Servo Amplifier

- ADA3-01NSE,02NSE
- ADA-R5LS,01LS,02LS,R5MS,01MS
- ADA-04LS,02MS (Values in < > are applied)

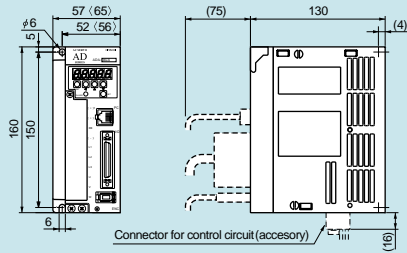

- ADA3-04NSE
- ADA-08LS,04MS

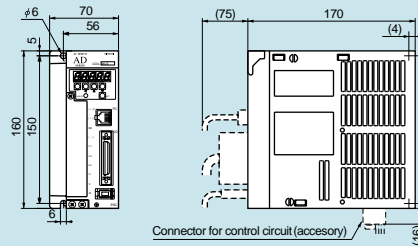

- ADA3-08NSE
- ADA-10LS,15LS (Values in < > are applied)

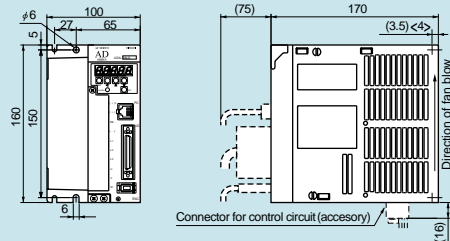

- ADA-20LS,30LS

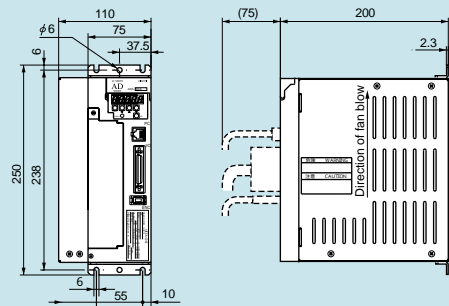

- ADA-50LS(45LS)

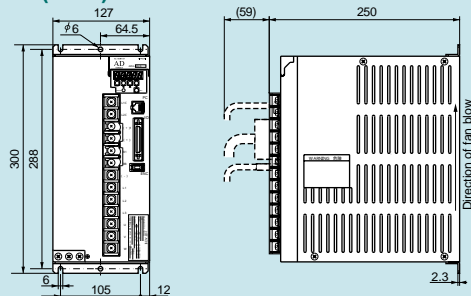

- ADA3-15HPE

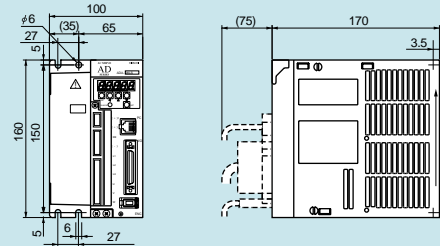

- ADA3-35HPE

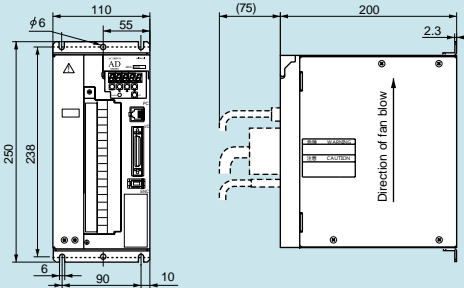

- ADA3-70HPE



Information in this brochure is subject to change without notice.

For further information, please contact your nearest sales representative.

**HITACHI**  
Inspire the Next