

Reduced to the best.

prime
cube®



Customized Computer Systems

**We concentrate on the essential.
To keep your mind free.**



**MSC Tuttlingen strikes out in a new direction:
with the innovative product brand Prime Cube.**

Performance means concentration. It is essential to leave out the irrelevant and only concentrate on things that count. Uncompromisingly we have realized this philosophy with our new product brand Prime Cube. The innovative generation of computers

follows an intelligent and highly flexible modular principle – each system is tailored to exactly suit the customers' requirements. Prime Cube is the visible expression of our technological competence and sums up our long-term experience in the world of



computer systems. And it is a prime example of the innovative strength of MSC Tuttlingen with its developers, engineers and designers. However, Prime Cube not only excels by innovation and performance but also by a unique and strong brand

personality reflected in every detail. Knowing what really matters: the precondition for intelligent system solutions.

Reduced to the best.



Contents

The brand Prime Cube

The best solution for computer-based applications

06

Prime Cube Modular System

The best solution based on modular design

12

Prime Cube Customized Design

The best solution for individual requirements

16

Prime Cube A-Line

The best solution for the attached panel PC

18

Prime Cube E-Line

The best solution for the enclosed/built-in panel PC

24

Prime Cube Systems Configurator

The best options at a glance

30



Reduced to the best.



Prime Cube. Simply the best solution.

Only if your computer system completely relieves you it is the right one. This is the Prime Cube principle. It is our claim to offer you from the start the best solution for your special requirement:

Customized Computer Systems. These are high-quality, innovative computer systems which are assembled from the modules of the Prime Cube Modular System to the Full Custom Design for any



individual requirement. With their modern, ergonomic design they set standards in terms of product aesthetics and user-friendliness. Prime Cube is the brand for demanding companies from all industries

trusting in German Engineering. The most efficient solution for any computer-based application. Prime Cube. Reduced to the best.

We do not follow models. But values.

Prime Cube stands for reliable values resulting from our long-term experience in the world of computer solutions. They motivate and characterize all services from our company and justify our brand promise: **Reduced to the best.**

Simplicity

How complex your requirements may be – the best solution makes everything easier. With efficient, practise-oriented computer systems we dissolve complexity and create performance potentials. In the project phase we relieve you by short distances, fast information and uncomplicated advice.

High Quality

German Engineering is the key to the high quality of our systems. Precision, quality and thoroughness determine our work at every step. To ensure at all times that your computer-based applications work exactly the way you thought they would.

Innovation

As we develop electronic solutions technological innovation is deeply rooted in our tradition and strictly geared towards customer use. Just like the Prime Cube Modular System and the principle to always achieve innovation on the component level. Therefore, you can always participate in the technological potential of your existing system application.

Individuality

From the application of the Prime Cube Modular System to Full Custom Design – we develop our computer systems perfectly tailored to your needs. With comprehensive understanding and an analytic view of the task and its implications. Only by this approach some solution will be the right solution for your requirements.

Reliability

We lay great emphasis on reliability and a long product life-cycle. Fail-safe components immune to interference and the long-term availability of our sturdy units for sustained process safety are our standard. As well as a customer support you can rely on for years.

Design

Our modern, functional and ergonomic product design sets standards. Units that not only convince by their design but also by their easy and intuitive use. With our products form always follows function. For comfortable use and distinct identity.

As unique as your requirements: our particular performance.

On the basis of our philosophy of values we strictly focus on the needs and goals of our customers.

We place highest demands on the efficiency of our solutions and the performance of our products and services. Discover the advantages our extraordinary service concept offers.

Complete Solutions

We develop complete solutions consisting of hardware plus software plus mechanics, precisely tuned to their immediate environment and users. We implement our precisely designed and exactly fitting computer systems and components with the professional know-how of the system integrator. Concentrated competence from task to solution.

Added Value Guarantee

We comprehensively analyze your needs and consider the respective task in its context - thus allowing for solutions with a real added value: more flexibility in the system defaults, more resources for future system adaptations, more cost-efficiency and more time for your own core competence.

Process Safety

Precision and reliability are key to system safety. This is why our solutions are safety-tested and certified. By means of optimized electrical, constructional and thermotechnical measures we meet all requirements and convince by permanent system availability and high functional safety.



Best Solution

Our customers being as manifold as their requirements we need great flexibility developing solutions. Just as offered by the Prime Cube Modular System. You can quite simply use standardized components or have them modified by us. And we develop the best solution for your extraordinary requirement.

Synergy Advantage

As we belong to the MSC group of companies we offer you the advantage of obtaining all project-relevant services from one hand. Our integrated range of services includes: general project management, an own board level portfolio, own development, own unit design, own production plants, and the world-wide procurement of components. Also a clear competitive advantage for you.

Investment Security

Intelligent solutions are sustainable. Our products convince by functional compatibility and user-friendliness as well as by easy maintenance and long-term availability. For all products we guarantee you five years of supply in terms of form/fit/function. You profit from a quick return on investment, a long and reliable product life-cycle and a competent partner always at hand for you.

All-Round Support

According to the motto "keep it simple" we make things as easy as possible for you: direct and flexible full-service support from the first consultation to the delivery and installation of your system solution. Even years later you profit from our reliable service and the best future solutions with subsequent system adaptations. We concentrate on the best support so that you can devote yourself to more important tasks.



Prime Cube Modular System.

The best solution based on modular design.

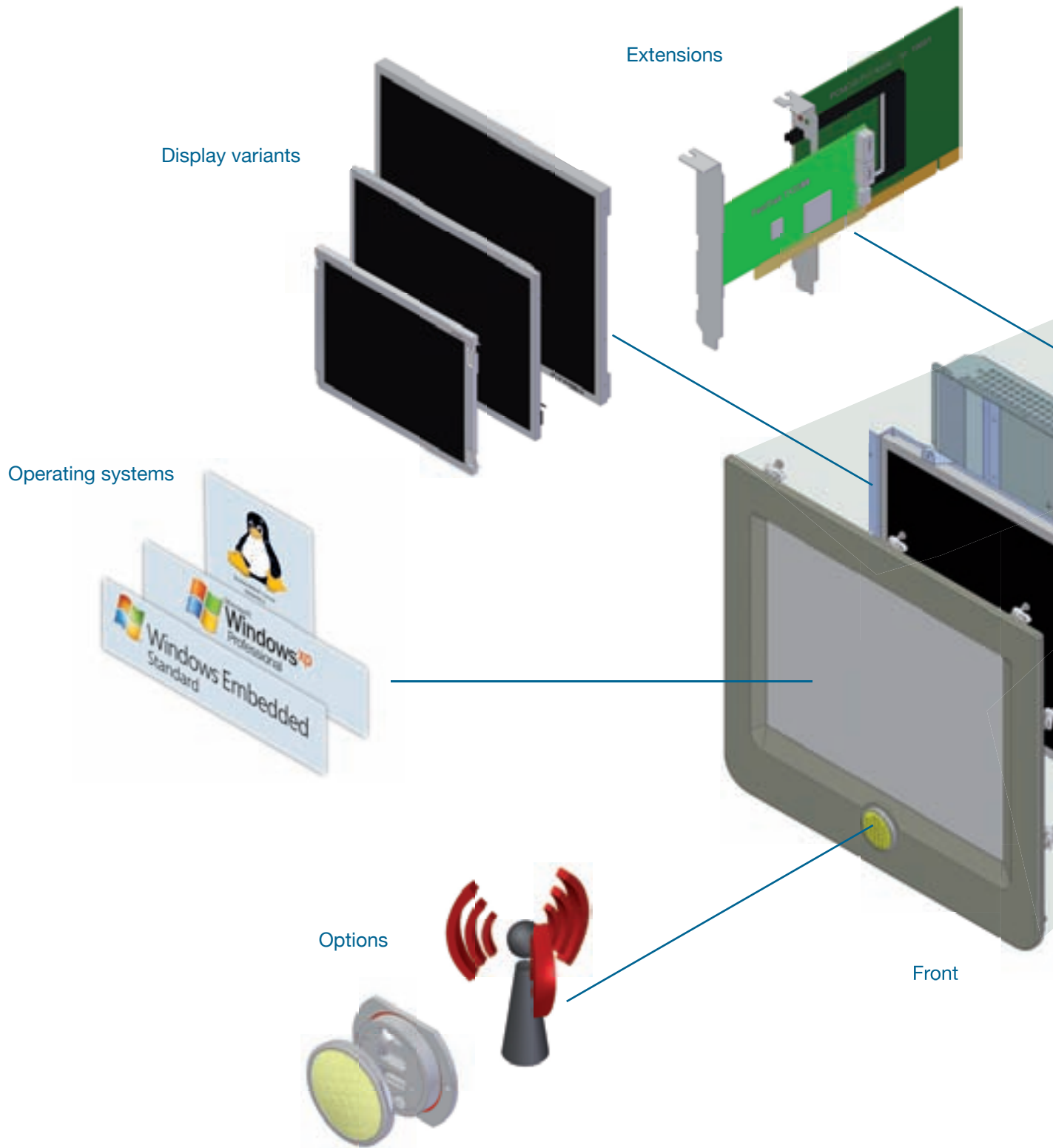

The Prime Cube Modular System is a concept that intelligently combines system-supporting modules depending on requirements. The best solution for exactly fitting system applications, simple extensions and flexibility when integrating future technologies.

The components and modules consistently geared to customer needs can be perfectly combined. The innovative precondition for the configuration of individual system variations – for hardware and software alike.

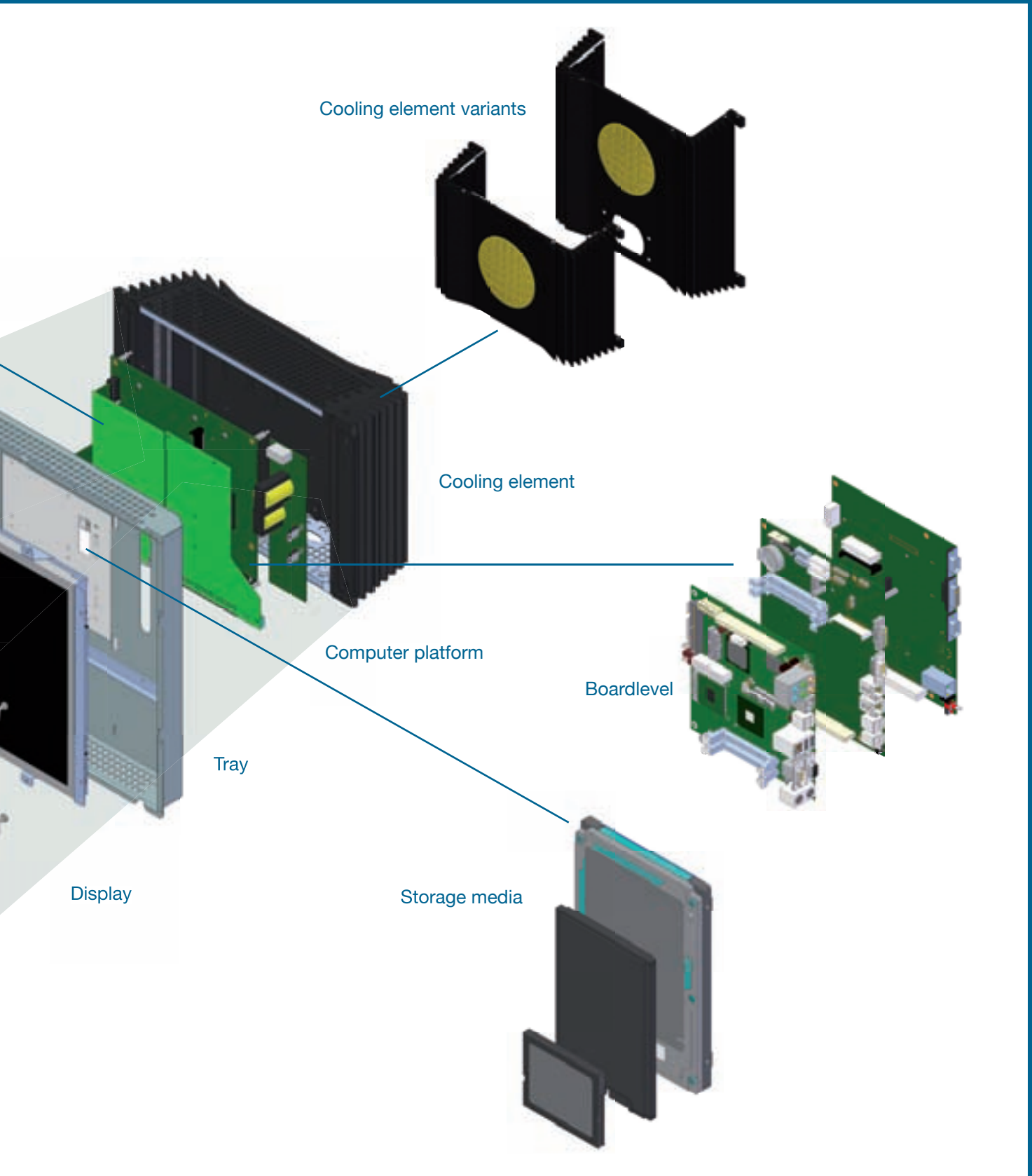

Modules for the individual system architecture.

The components and their respective characteristics.

Computer Platforms

Scalable CPU-performance from Atom to Core-2-Duo processors. Compatible design of the computer cores, based on three architectures: "SBC" (single-board computer) – preferably for general operating and visualising tasks, "CXB" (COM-Express) – ideally suited for embedded controls with real-time requirements, and "ITX" – the open platform with high PC-performance at low costs. All computer platforms bridge short times of power failure to increase the systems safety.

Display Variants

No matter if data entry, process visualization or parameterization – you can choose the most suitable screen size for your application out of three standardized formats: 30.7 cm/38.1 cm/48.3 cm (12.1"/15"/19"). The high-quality TFT-displays primarily excel by the features relevant for use in industrial applications: They are luminous, rich in contrast and durable (high MTBF). Furthermore, they can be used vertically as well as horizontally and offer the operator a wide viewing angle.

Frontend Design

Depending on the requirement the IPC-fronts with touch screen can be selected specifically – both in terms of housing type (enclosed, attached) and material (stainless steel, aluminium, steel sheet and plastics) and of surface finishing (varnished, anodized). The Clean-Line-Technology offered for the stainless steel housing supports GMP-compliant models for use under hygiene requirements (pharmaceutical and food industry). Furthermore, the equipment of additional operating elements (e.g. buttons, emergency switches) is possible.

Operating Systems

Apart from Windows XP Prof. we offer comprehensive support for embedded operating systems with performance-optimized system adaptation. The images created specifically for the respective use with Windows Embedded Standard guarantee high system performance with minimized hardware resources. A separate Linux distribution allows for the free adaptation of the open source components and meets hard real-time criteria with extended functionality. By planning a Hypervisor the systems can be used in combination and operated in parallel mode.

Computer Housing

There are four types of cooling elements to accommodate the computer cores. Basically, the types for the attached resp. enclosed panels are distinguished by two format sizes with two installation depths each: The “Small” cooling element is designed for energy-efficient CPUs with low power consumption (SBC), while the “Compact” version integrates high CPU-performance (CXB, ITX). Both can host a plug-in card to extend the functionality. The innovative heat emission concept allows for a continuously fanless CPU and system cooling.

Storage Media

Among other mass storage devices highly shock and vibration-tolerant drives (HDD) as well as semiconductor hard disks (SSD) and Compact-Flash cards (CF) are available. Furthermore, in order to achieve an optimum adaptation, a combined configuration of the storage devices in one system is possible. So the Embedded Operating System might be write-protected on CF, while the continuous data acquisition is written to a hard disk. The MRAM-extension allows for the storage of remanent data and increases the system safety in the case of power failure.

Extension Components

The great variety of tasks to be completed results in manifold requirements. For any case “suitable” additions are available. PCI and PCI-Express modules, field-bus interface as well as an I/O module (24 inputs/outputs which are freely configurable) allow for the integration of peripheral resp. additional system functions. On the software side common Soft-PLC and visualization/SCADA software packages can be installed. New variants and components – geared to customer needs – are permanently updated.

Optional Functions

In order to further modify the system with application-specific features the respective functions can be integrated on request: both WLAN as well as RFID-readers or barcode scanners, or on the front side a USB-port under protected IP65-cover (alternatively on the rear side at the computer core) or additional operating elements in variable number – the options are manifold. Further options are determined by future technologies and can be taken up successively.

From Prime Cube Modular System to Full Custom Design.

Special projects require special measures.

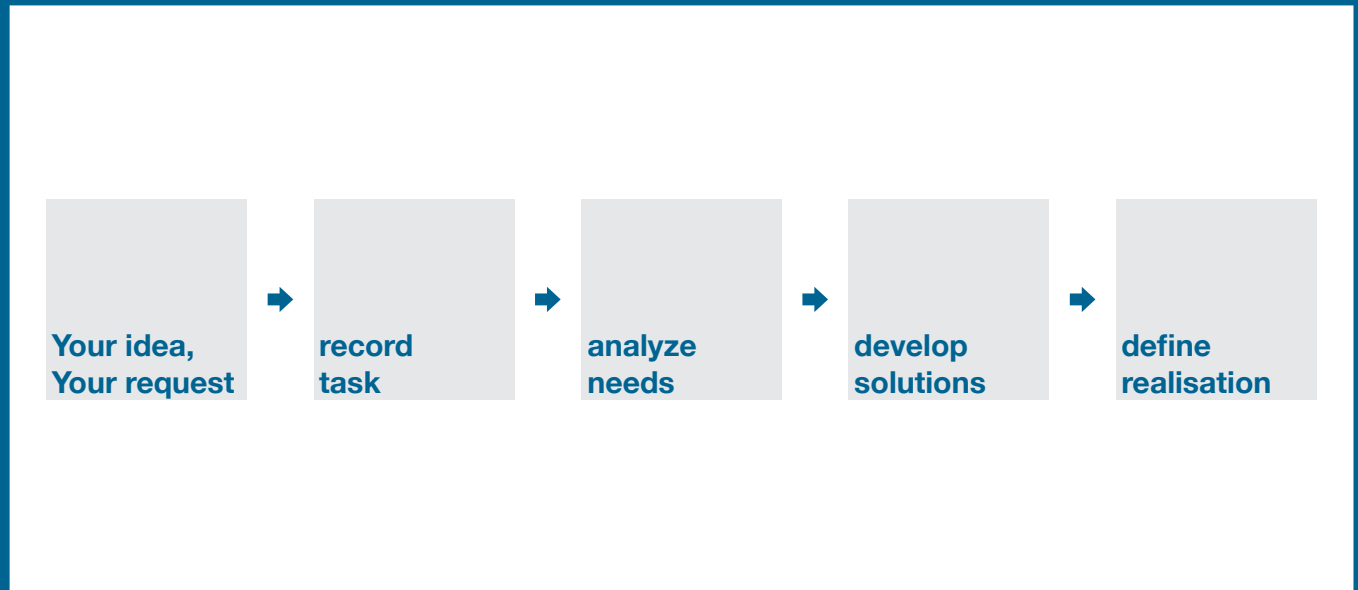

Customizing means adaptation or individual solution. In principle, almost anything is possible. However, for the selection of the means the end to be achieved is always important: Reduced to the best.

Whatever you require: our flexible offer will certainly be the direct way to the best solution, for small and simple projects as well as for high-end specifications.

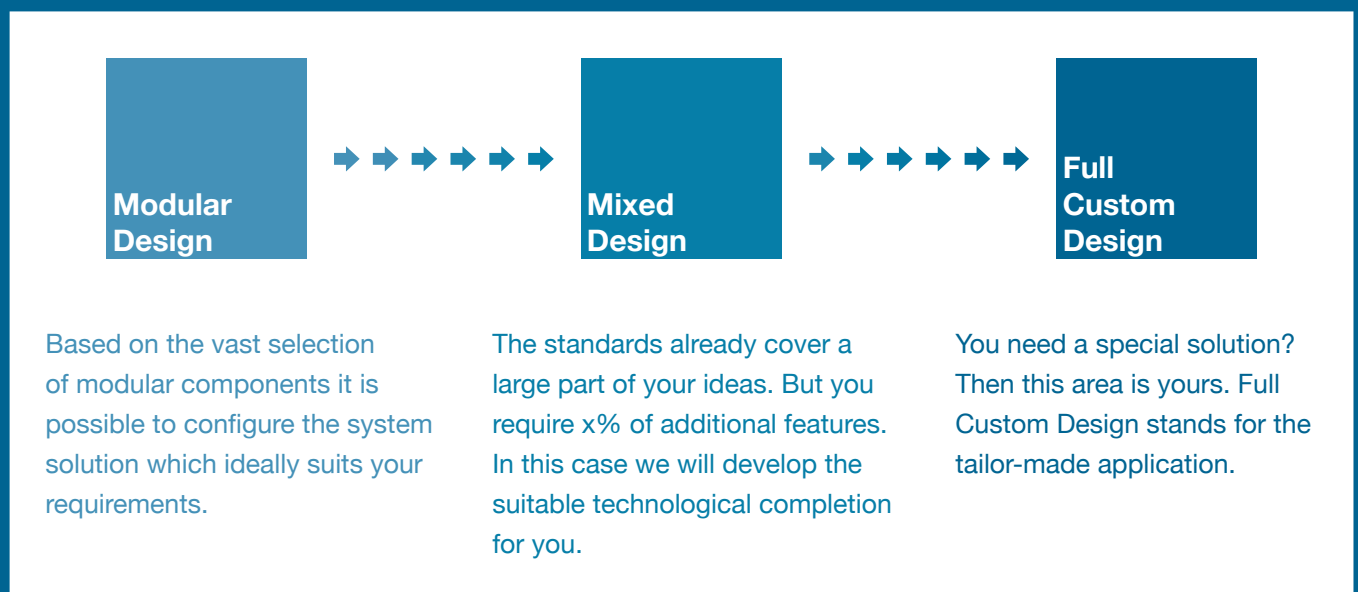

Full Custom Design means: We will competently and professionally transform your project ideas into independent products – in close cooperation with

you. Profit from technological know-how and many years of application experience – our “German Engineering”!



Electronics

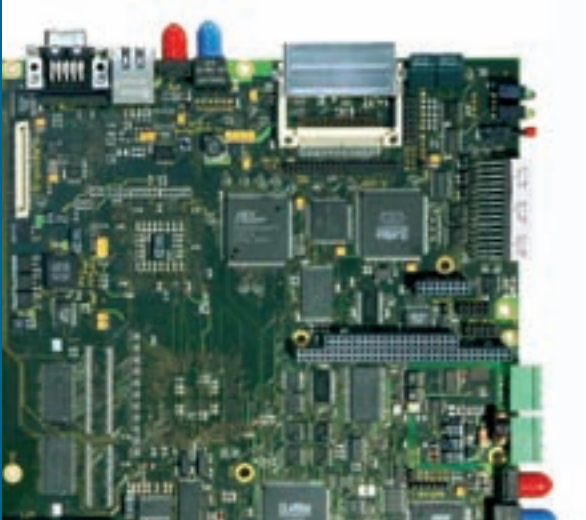

- Modification of computer platforms
- Integration of function-specific hardware
- Configuration of field bus and networks
- Optimization of power consumption / cooling

Mechanics



- Design / adaptation of hardware
- Best ergonomic design possible
- Individual adaptation to machine concept
- Company branding / look & feel

Software



- Integration of other operating systems
- Implementation of firmware
- Development of configuration interfaces
- Programming of specific functions

Your profile



- What are your needs?
- Which are your system requirements?
- Do you want module or turnkey system?
- Would you like a typical industry solution?

Reduced to the best.



Prime Cube A-Line.

The best solution for the attached panel PC.



Prime Cube A-Line is the product family for stand-alone solutions. The panels are particularly designed for use in process-oriented environments.

Independent of the control cabinets they can be installed precisely where they are needed as operator stations.

**Performance in
high-quality outfit.**





- Mounting via flange on rear side
- Adaptation to all support arm/pedestal systems
- Angled position for ergonomic handling
- Quick adaptation of the device system to operating requirements



- The front plate layout allows to provide for special interface functions (e.g. USB, RFID) under protected IP65-cover
- Application-specific arrangement through integration of additional operating elements (e.g. buttons, emergency switches) which can be laid out individually



- High-quality stainless steel housing without beadings or edges
- Ideally suited for complete encapsulation of housing acc. protection class IP65
- Available as GMP-compliant hygiene model, perfect for clean room applications (food and pharmaceutical industry)



- Cable connection in protected area, simple cable installation
- Service access supports the integration-friendly with front extensions or in a service case

Prime Cube A-Line. Attached Panel PC.

The system specifications provide you with an overview of the variants available and their data.
Technical changes reserved. Please contact us for further information.

Panel PC with display 30.7 cm (12")

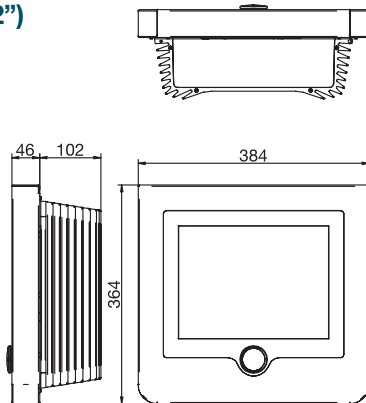

Panel PC with display 38.1 cm (15")

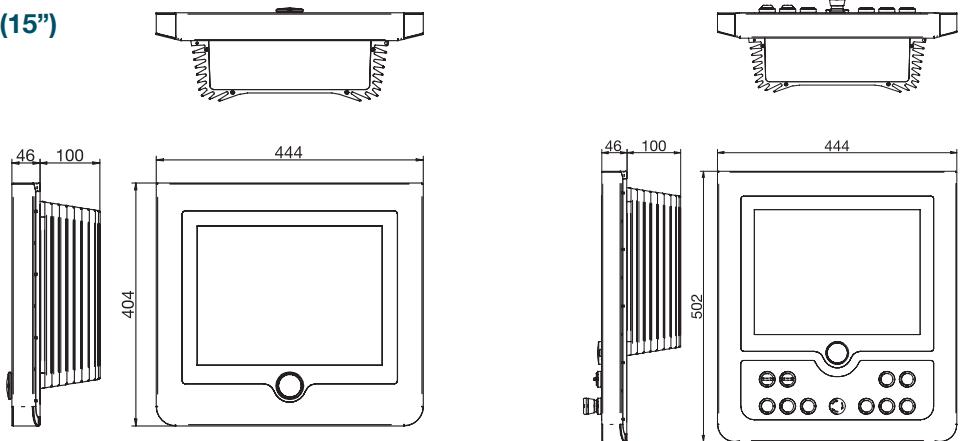

Panel PC with display 48.3 cm (19")

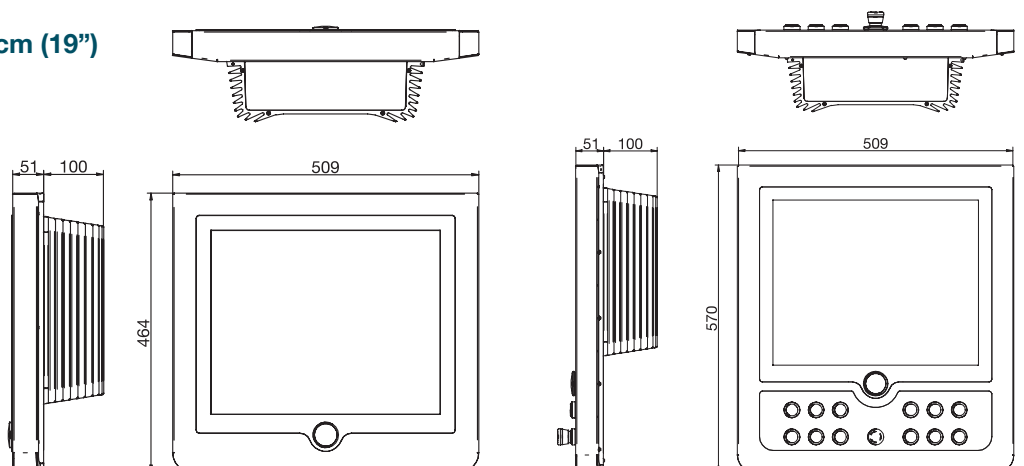

	SBC platform	CXB platform	ITX platform
Housing	<ul style="list-style-type: none"> ■ Mechanically stable stainless steel housing (V2A) in industrial, EMC-compliant design with integrated flange connection ■ Hygiene design without beadings and edges ■ Dirt-proof surface sealing "Clean Line" optional ■ System version also available with varnished steel sheet housing ■ Flange connection adapter for common support arm and pedestal systems 		
Front plate	<ul style="list-style-type: none"> ■ Stainless steel front (V2A) with integrated touch screen (analog-resistiv) ■ Inserted GMP-foil for plane, smooth surface ■ Front of model with steel sheet housing also comes in varnished steel sheet ■ 2x USB 2.0 under IP65-protected cover (optional) ■ Optional with insert plate for RFID-reader or control devices, e.g. buttons, emergency switches 		
Protection class	■ IP65 all round		
Display	■ 30.7 cm (12.1") TFT (SVGA), 38.1 cm (15") TFT (XGA), 48.3 cm (19") TFT (SXGA)		
Baseboard/ CPU-module	<ul style="list-style-type: none"> ■ Single-board Computer ■ CPU: Intel Atom N270 (1,60 GHz) ■ Chip set: Intel 945 GSE 	<ul style="list-style-type: none"> ■ Long-term availability of baseboard, application-specific development for the reception of COM-Express modules ■ CPU: Intel Celeron M 440 (1.86 GHz) resp. Intel Core Duo L2400 (2x 1.66 GHz) ■ Chip set: Intel 945 GM 	<ul style="list-style-type: none"> ■ Industrial standard board ■ CPU: Intel Celeron M 722 (1.20 GHz), Intel Celeron 575 (2.00 GHz) or Intel Core 2 Duo T9400 (2x 2.53 GHz) ■ Chip set: Intel GM 45
Cooling	■ Fanless CPU and system cooling		
Main memory	■ Up to 2 GB DDR2-RAM	<ul style="list-style-type: none"> ■ Up to 2 GB DDR2-RAM ■ Up to 2 MB MRAM for storage of remanent data 	■ Up to 4 GB DDR2-RAM
Hard disc/ CompactFlash	<ul style="list-style-type: none"> ■ 2x CompactFlash up to 8 GB each (1x write-protected for operating system, 1x for user data) ■ Alternatively hard disk with 80 GB or more 	<ul style="list-style-type: none"> ■ 2x CompactFlash up to 8 GB each (1x write-protected for operating system, 1x for user data) ■ Alternatively hard disk with 80 GB or more 	■ Hard disk with 80 GB or more, 2nd hard disk optional
Interfaces	<ul style="list-style-type: none"> ■ 4x (6x) USB 2.0 ■ 2x Ethernet 10/100/1000 Mbps ■ 2x RS232 (1x internal/1x external) ■ 1x DVI-I 	<ul style="list-style-type: none"> ■ 4x (6x) USB 2.0 ■ 3x Ethernet 10/100/1000 Mbps ■ 2x COM (RS232 + RS232/485) ■ 1x CAN interface ■ 1x DVI-I ■ 3x status LEDs, freely progr. ■ Run-stop-switch 	<ul style="list-style-type: none"> ■ 4x (6x) USB 2.0 ■ 2x Ethernet 10/100/1000 Mbps ■ 1x RS232 ■ 1x VGA ■ 1x DVI-I
Slots	■ 1x PCI/1x PCI Express x1, one slot usable, alternatively field bus extension	<ul style="list-style-type: none"> ■ 1x I/O extension ■ 1x PCI/1x PCI Express x1, one slot usable, alternatively field bus extension 	■ 1x PCI/1x PCI Express x1, one slot usable, alternatively field bus extension
Supply voltage	■ 24 V DC (19 ... 36 V DC)		
Ambient temperature during operation	■ 0 °C to +50 °C	■ 0 °C to +50 °C	■ +5 °C to +45 °C
Mark of conformity	■ CE, approval for the North American market in preparation		
Operating system	<ul style="list-style-type: none"> ■ Windows Embedded Standard ■ Embedded Linux ■ Windows XP Prof. (only in combination with hard disk) 	<ul style="list-style-type: none"> ■ Windows Embedded Standard ■ Embedded Linux ■ Windows XP Prof. (only in combination with hard disk) 	<ul style="list-style-type: none"> ■ Windows XP Prof. ■ Linux distribution on request
Further software	■ Visualization, Soft-PLC and others on request		
Further variants and options	■ On request		

Reduced to the best.



Prime Cube E-Line.

The best solution for the enclosed/built-in panel PC.



Prime Cube E-Line is a product family whose panels are designed for all kinds of installation fronts of plants or facilities.

The universal mounting and the swivelling computer housing guarantee a high degree of installation flexibility.



**Functionality
smartly integrated.**



- New mounting technology allows for easy panel installation
- Due to the clever quick-fix-mounting no borings are required in control cabinets, front panels and consoles
- Type-specific shaping of cooling elements depending on computer performance



- Swift-lock-concept allows for swivel-mounted installation of computer housing (cooling element)
- Service-friendly direct access to all major system components



- Compatible design of scalable computer platforms
- Fanless system cooling, consistently in all CPU performance classes
- Type-specific power supply components for energy-efficient supply



- Modern profile for independent identity in customer's corporate design
- Luminous TFT-displays support the ease of use by optimum viewing angle, clear readability and easy usability of touch screen

Prime Cube E-Line. Enclosed/built-in Panel PC.

The system specifications provide you with an overview of the variants available and their data.
Technical changes reserved. Please contact us for further information.

Panel PC with display 30.7 cm (12,1")

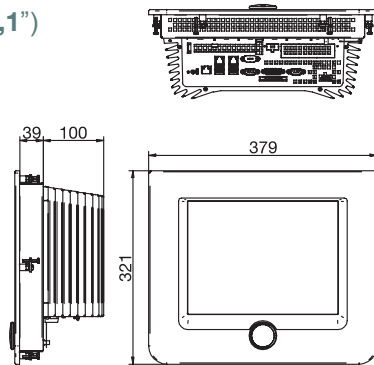

Panel PC with display 38.1 cm (15")

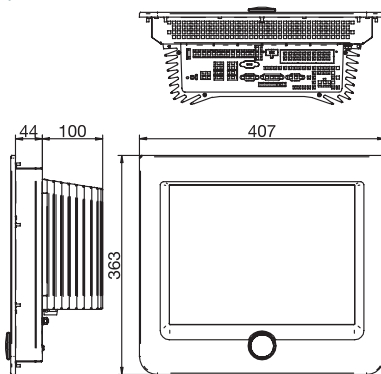

Panel PC with display 48.3 cm (19")

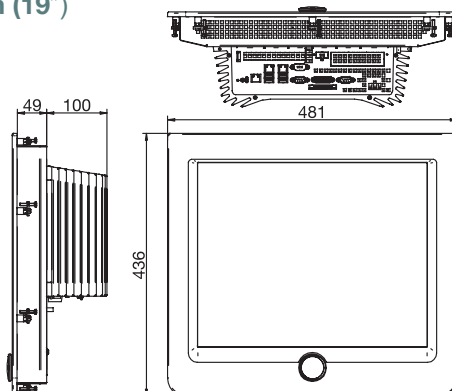

	SBC platform	CXB platform	ITX platform
Housing	<ul style="list-style-type: none"> ■ Mechanically stable varnished steel sheet housing for mounting into control cabinets, consoles and pivot frames ■ Industrial, EMC-compliant housing design 		
Front plate	<ul style="list-style-type: none"> ■ Aluminium front plate, surface varnished, grants protection from dust, dirt and spray water by seamless sealing ■ Further materials in preparation ■ Integrated touch screen (analog-resistiv) ■ 2x USB 2.0 under IP65-protected cover (optional) 		
Protection class	<ul style="list-style-type: none"> ■ Front IP65, rear side IP20 		
Display	<ul style="list-style-type: none"> ■ 30.7 cm (12.1") TFT (SVGA), 38.1 cm (15") TFT (XGA), 48.3 cm (19") TFT (SXGA) 		
Baseboard/ CPU-module	<ul style="list-style-type: none"> ■ Single-board computer ■ CPU: Intel Atom N270 (1.60 GHz) ■ Chip set: Intel 945 GSE 	<ul style="list-style-type: none"> ■ Long-term availability of baseboard application-specific development for the reception of COM-Express modules ■ CPU: Intel Celeron M 440, (1.86 GHz) resp. Intel Core Duo L2400 (2x 1.66 GHz) ■ Chip set: Intel 945 GM 	<ul style="list-style-type: none"> ■ Industrial standard board ■ CPU: Intel Celeron M 722 (1.20 GHz), Intel Celeron 575 (2.00 GHz) or Intel Core 2 Duo T9400 (2x 2.53 GHz) ■ Chip set: Intel GM 45
Cooling	<ul style="list-style-type: none"> ■ Fanless CPU and system cooling 		
Main memory	<ul style="list-style-type: none"> ■ Up to 2 GB DDR2-RAM 	<ul style="list-style-type: none"> ■ Up to 2 GB DDR2-RAM ■ Up to 2 MB MRAM for storage of remanent data 	<ul style="list-style-type: none"> ■ Up to 4 GB DDR2-RAM
Hard disk/ CompactFlash	<ul style="list-style-type: none"> ■ 2x CompactFlash up to 8 GB each (1x write-protected for operating system, 1x for user data) ■ Alternatively hard disk with 80 GB or more 	<ul style="list-style-type: none"> ■ 2x CompactFlash up to 8 GB each (1x write-protected for operating system, 1x for user data) ■ Alternatively hard disk with 80 GB or more 	<ul style="list-style-type: none"> ■ Hard disk with 80 GB or more, 2nd hard disk optional
Interfaces	<ul style="list-style-type: none"> ■ 4x (6x) USB 2.0 ■ 2x Ethernet 10/100/1000 Mbps ■ 2x RS232 (1x internal/1x external) ■ 1x DVI-I 	<ul style="list-style-type: none"> ■ 4x (6x) USB 2.0 ■ 3x Ethernet 10/100/1000 Mbps ■ 2x COM (RS232 + RS232/485) ■ 1x CAN interface ■ 1x DVI-I ■ 3x status LEDs, freely progr. ■ Run-stop-switch 	<ul style="list-style-type: none"> ■ 4x (6x) USB 2.0 ■ 2x Ethernet 10/100/1000 Mbps ■ 1x RS232 ■ 1x VGA ■ 1x DVI-I
Slots	<ul style="list-style-type: none"> ■ 1x PCI/1x PCI Express x1, one slot usable, alternatively field bus extension 	<ul style="list-style-type: none"> ■ 1x I/O-Erweiterung ■ 1x PCI/1x PCI Express x1, one slot usable, alternatively field bus extension 	<ul style="list-style-type: none"> ■ 1x PCI/1x PCI Express x1, one slot usable, alternatively field bus extension
Supply voltage	<ul style="list-style-type: none"> ■ 24 V DC (19 ... 36 V DC) 		
Ambient temperature during operation	<ul style="list-style-type: none"> ■ 0 °C to +50 °C 	<ul style="list-style-type: none"> ■ 0 °C to +50 °C 	<ul style="list-style-type: none"> ■ +5 °C to +45 °C
Mark of conformity	<ul style="list-style-type: none"> ■ CE, approval for the North American market in preparation 		
Operating system	<ul style="list-style-type: none"> ■ Windows Embedded Standard ■ Embedded Linux ■ Windows XP Prof. (only in combination with hard disk) 	<ul style="list-style-type: none"> ■ Windows Embedded Standard ■ Embedded Linux ■ Windows XP Prof. (only in combination with hard disk) 	<ul style="list-style-type: none"> ■ Windows XP Prof. ■ Linux distribution on request
Further software	<ul style="list-style-type: none"> ■ Visualization, Soft-PLC and others on request 		
Further variants and options	<ul style="list-style-type: none"> ■ On request 		

Prime Cube System Configurator.

The best options at a glance.

Prime Cube A-Line

Platform:	ITX	CXB	SBC
Frontend			
Stainless steel V2A (GMP-compliant)	<input type="checkbox"/>	<input type="checkbox"/>	<input type="checkbox"/>
Aluminium, varnished			
Other materials	on request	on request	on request
Control devices ⁽¹⁾	<input type="checkbox"/>	<input type="checkbox"/>	<input type="checkbox"/>
USB ⁽²⁾	<input type="checkbox"/>	<input type="checkbox"/>	<input type="checkbox"/>
Housing shape/cooling element			
Compact	<input type="checkbox"/>	<input type="checkbox"/>	
Small			<input type="checkbox"/>
Display			
30.7 cm/38.1 cm/48.3 cm (12.1"/15"/19")	<input type="checkbox"/> / <input type="checkbox"/> / <input type="checkbox"/>	<input type="checkbox"/> / <input type="checkbox"/> / <input type="checkbox"/>	<input type="checkbox"/> / <input type="checkbox"/> / <input type="checkbox"/>
Protection Class front end/rear end (IPxx)	65/65	65/65	65/65
CPU			
Atom N270 (1.60 GHz)			<input type="checkbox"/>
Celeron M 440 (1.86 GHz)		<input type="checkbox"/>	
Core Duo L2400 (2x 1.66 GHz)		<input type="checkbox"/>	
Celeron 575 (2.00 GHz)	<input type="checkbox"/>		
Celeron M 722 (1.20 GHz)	<input type="checkbox"/>		
Core 2 Duo T9400 (2x 2.53 GHz)	<input type="checkbox"/>		
Fanless CPU and system cooling	<input type="checkbox"/>	<input type="checkbox"/>	<input type="checkbox"/>
Main memory			
Max. (DDR2-RAM)	4 GB	2 GB	2 GB
MRAM 512 KB ⁽⁶⁾		<input type="checkbox"/>	
Hard disks/drives			
Hard disk "generic" min. 80 GB ⁽⁷⁾	<input type="checkbox"/>	<input type="checkbox"/>	<input type="checkbox"/>
SSD min. 32 GB	<input type="checkbox"/>	<input type="checkbox"/>	<input type="checkbox"/>
RAID	<input type="checkbox"/>		
CompactFlash-Card min. 1 GB		<input type="checkbox"/>	<input type="checkbox"/>
2nd CF-Card		<input type="checkbox"/>	<input type="checkbox"/>
Hard disks as 2nd or 3rd drive	<input type="checkbox"/>	<input type="checkbox"/>	<input type="checkbox"/>
Interfaces			
Ethernet 10/100/1000 Gbit	2	3 ⁽³⁾	2 ⁽³⁾
USB 2.0, rear end	4	4	4
USB 2.0, front end (2x)	<input type="checkbox"/>	<input type="checkbox"/>	<input type="checkbox"/>
RS232	1	2 ⁽⁴⁾	2 ⁽⁵⁾
CAN		<input type="checkbox"/>	
DVI-I	<input type="checkbox"/>	<input type="checkbox"/>	<input type="checkbox"/>
VGA	<input type="checkbox"/>		
I/O extension (24 I/O)		<input type="checkbox"/>	
Fieldbus extension	<input type="checkbox"/>	<input type="checkbox"/>	<input type="checkbox"/>
Slot (PCI/PCI-Express)⁽⁸⁾	<input type="checkbox"/>	<input type="checkbox"/>	<input type="checkbox"/>
Supply voltage 24 V DC (19 ... 36 V DC)	<input type="checkbox"/>	<input type="checkbox"/>	<input type="checkbox"/>
Operating temperature			
+5 °C up to +45 °C	<input type="checkbox"/>		
0 °C up to +50 °C ⁽⁹⁾		<input type="checkbox"/>	<input type="checkbox"/>
Operating systems			
Windows XP Prof.	<input type="checkbox"/>		
Windows Embedded Standard		<input type="checkbox"/>	<input type="checkbox"/>
Embedded Linux		<input type="checkbox"/>	<input type="checkbox"/>
Linux distribution (e.g. SUSE) on request	<input type="checkbox"/>		

The Prime Cube system configurator provides you with a quick orientation which combination will be practical and useful for your system and which

system combination cannot be realized for reasons of system technology. So that functionality, flexibility and quality of the total system will always be granted.

Prime Cube E-Line

Platform:	ITX	CXB	SBC
Frontend			
Stainless steel V2A (GMP-compliant)	<input type="checkbox"/>	<input type="checkbox"/>	<input type="checkbox"/>
Aluminium, varnished	<input type="checkbox"/>	<input type="checkbox"/>	<input type="checkbox"/>
Other materials	on request	on request	on request
Control devices ⁽¹⁾			
USB ⁽²⁾	<input type="checkbox"/>	<input type="checkbox"/>	<input type="checkbox"/>
Housing shape/cooling element			
Compact	<input type="checkbox"/>	<input type="checkbox"/>	<input type="checkbox"/>
Small	<input type="checkbox"/>	<input type="checkbox"/>	<input type="checkbox"/>
Display			
30.7 cm/38.1 cm/48.3 cm (12.1"/15"/19")	<input type="checkbox"/> / <input type="checkbox"/> / <input type="checkbox"/>	<input type="checkbox"/> / <input type="checkbox"/> / <input type="checkbox"/>	<input type="checkbox"/> / <input type="checkbox"/> / <input type="checkbox"/>
Protection Class front end/rear end (IPxx)	65/20	65/20	65/20
CPU			
Atom N270 (1.60 GHz)	<input type="checkbox"/>	<input type="checkbox"/>	<input type="checkbox"/>
Celeron M 440 (1.86 GHz)	<input type="checkbox"/>	<input type="checkbox"/>	<input type="checkbox"/>
Core Duo L2400 (2x 1.66 GHz)	<input type="checkbox"/>	<input type="checkbox"/>	<input type="checkbox"/>
Celeron 575 (2.00 GHz)	<input type="checkbox"/>	<input type="checkbox"/>	<input type="checkbox"/>
Celeron M 722 (1.20 GHz)	<input type="checkbox"/>	<input type="checkbox"/>	<input type="checkbox"/>
Core 2 Duo T9400 (2x 2.53 GHz)	<input type="checkbox"/>	<input type="checkbox"/>	<input type="checkbox"/>
Fanless CPU and system cooling	<input type="checkbox"/>	<input type="checkbox"/>	<input type="checkbox"/>
Main memory			
Max. (DDR2-RAM)	4 GB	2 GB	2 GB
MRAM 512 KB ⁽⁶⁾	<input type="checkbox"/>	<input type="checkbox"/>	<input type="checkbox"/>
Hard disks/drives			
Hard disk "generic" min. 80 GB ⁽⁷⁾	<input type="checkbox"/>	<input type="checkbox"/>	<input type="checkbox"/>
SSD min. 32 GB	<input type="checkbox"/>	<input type="checkbox"/>	<input type="checkbox"/>
RAID	<input type="checkbox"/>	<input type="checkbox"/>	<input type="checkbox"/>
CompactFlash card min. 1 GB	<input type="checkbox"/>	<input type="checkbox"/>	<input type="checkbox"/>
2nd CF-Card	<input type="checkbox"/>	<input type="checkbox"/>	<input type="checkbox"/>
Hard disks as 2nd or 3rd drive	<input type="checkbox"/>	<input type="checkbox"/>	<input type="checkbox"/>
Interfaces			
Ethernet 10/100/1000 Gbit	2	3 ⁽³⁾	2 ⁽³⁾
USB 2.0, rear end	4	4	4
USB 2.0, front end (2x)	<input type="checkbox"/>	<input type="checkbox"/>	<input type="checkbox"/>
RS232	1	2 ⁽⁴⁾	2 ⁽⁵⁾
CAN	<input type="checkbox"/>	<input type="checkbox"/>	<input type="checkbox"/>
DVI-I	<input type="checkbox"/>	<input type="checkbox"/>	<input type="checkbox"/>
VGA	<input type="checkbox"/>	<input type="checkbox"/>	<input type="checkbox"/>
I/O extension (24 I/O)	<input type="checkbox"/>	<input type="checkbox"/>	<input type="checkbox"/>
Fieldbus extension	<input type="checkbox"/>	<input type="checkbox"/>	<input type="checkbox"/>
Slot (PCI/PCI-Express)⁽⁶⁾	<input type="checkbox"/>	<input type="checkbox"/>	<input type="checkbox"/>
Supply voltage 24 V DC (19 ... 36 V DC)	<input type="checkbox"/>	<input type="checkbox"/>	<input type="checkbox"/>
Operating temperature			
+5 °C up to +45 °C	<input type="checkbox"/>	<input type="checkbox"/>	<input type="checkbox"/>
0 °C up to +50 °C ⁽⁹⁾	<input type="checkbox"/>	<input type="checkbox"/>	<input type="checkbox"/>
Operating systems			
Windows XP Prof.	<input type="checkbox"/>	<input type="checkbox"/>	<input type="checkbox"/>
Windows Embedded Standard	<input type="checkbox"/>	<input type="checkbox"/>	<input type="checkbox"/>
Embedded Linux	<input type="checkbox"/>	<input type="checkbox"/>	<input type="checkbox"/>
Linux distribution (e.g. SUSE) on request	<input type="checkbox"/>	<input type="checkbox"/>	<input type="checkbox"/>

Legend: standard equipment
 optional
⁽¹⁾ with 30.7cm (12.1") display max. 8, 38.1cm (15") max. 10, 48.3cm (19") max. 12, in each case plus emergency switch

⁽²⁾ 2 interfaces under IP65-protected cover.
⁽³⁾ 2 of them real-time capable.
⁽⁴⁾ 1 of them optional as RS232/-422/-485.
⁽⁵⁾ 1 of them internal.
⁽⁶⁾ extensible up to 2 MB.
⁽⁷⁾ hard disks for continuous operation (24/7) and with

extended shock and vibration resistance optional.
⁽⁸⁾ not usable in combination or in connection with field bus extension.
⁽⁹⁾ +5°C to +45°C with hard disk option.
 All data without customer-specific extensions.
 Technical changes reserved.

Reduced to the best.

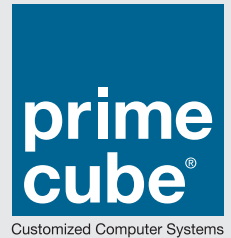

www.primecube.de

Edition 02/10

© MSC Tuttlingen GmbH. All rights reserved. All data are non-binding and do not constitute assured properties. We do not assume any liability for printing errors. Changes reserved. Even without special identification the company names and logos used are usually protected by copyright and/or trademark right. All product names used are trade names and/or trademarks of the respective manufacturer.



MSC Microcomputers Systems Components Tuttlingen GmbH

Rudolf-Diesel-Straße 17 ■ 78532 Tuttlingen ■ Germany ■ Tel. +49 7461 925-200 ■ sales@msc-tuttlingen.de